

# Autonomous Smart Window

EEL 4914 - Senior Design I

Dr. Lei Wei

December 7, 2020

University of Central Florida  
Department of Electrical and Computer Engineering  
College of Optics and Photonics



Fall Term 2020 - Group 7

Nomar Barreto - Electrical Engineering

Bradley Howder - Photonic Science and Engineering

Abdullah Husain - Photonic Science and Engineering

Kenneth Sauers - Computer Engineering

# Table of Contents

<b>1. Executive Summary</b>	<b>1</b>
<b>2. Project Description</b>	<b>2</b>
<b>2.1 Project Motivation and Goals</b>	<b>2</b>
<b>2.2 Proposal and Objectives</b>	<b>3</b>
<b>2.3 Qualitative Specifications</b>	<b>3</b>
Window and Film Specifications	4
Electrical and Computer Specifications	5
Sensor Specifications and Descriptions	5
PIR Motion Sensor	5
Optical Photometer	5
<b>2.4 House of Quality Analysis</b>	<b>6</b>
<b>2.5 Block Diagram</b>	<b>8</b>
<b>2.6 Summary of Quantitative Specifications and Deliverables</b>	<b>9</b>
<b>3. Project Research and Part Selection</b>	<b>11</b>
<b>3.1 Similar Projects and Existing Products</b>	<b>11</b>
<b>3.2 Relevant Technologies</b>	<b>13</b>
Motion and Torque Transfer	13
Gears	13
Pulley and Belt	14
Sprocket and Chain	14
Fabrication Techniques	14
3D Printing	14
Plasma Cutting	15
Laser Cutting	15
CNC Mill	15
User Interactions	15
Wi-Fi	16
Bluetooth	16
ZigBee	16
LCD and Buttons	16
Mobile Bluetooth Application	17
Native Android Studio	17

Flutter	17
React Native	17
Processor	18
ESP32 Breakout Board	18
Texas Instruments MSP430G2553	19
Arduino Nano	19
Raspberrypi	19
Power Supply	19
Batteries	19
AC-DC Wall Adapter	20
USB Cable	21
Rotating Mechanism	21
Motor Driver	21
Types of Motors	23
DC Motors	23
Stepper Motors	24
Servo Motors	26
Tinting Mechanism	29
Photochromic Film	29
Electrically Controlled Blinds	30
Rotating Polarizers	31
Privacy Screen	32
Reflective Polarizer	32
PDLC Film	33
One-way Mirror	35
Colorful Lighting Mechanism	36
Color Changing LEDs	36
Sensors and Detectors	37
Video Camera Motion Sensor	37
Ultrasonic Motion Sensor	38
Microwave Motion Detector	42
Passive Infrared Motion Sensor	43
Light Dependant Resistor	45
Luminance and Illuminance Photometer	46
<b>3.3 Strategic Part Selection</b>	<b>49</b>
Tinting Mechanism	49
Summary	51
Privacy Screen	51

Summary	52
Color-Changing LEDs	52
Summary	53
Motion Sensor	53
Summary	54
PIR Motion Sensor	55
Summary	56
Light Detector	57
Power Supply	60
Motor Driver Selection	63
Motor Selection	66
User Interaction	68
Summary	68
Fabrication Technique	68
Summary	69
Processor	69
Summary	70
Mobile Application Framework	70
Power Supply	70
Summary	71
Motion and Torque Transfer	71
<b>4. Design Standards and Constraints</b>	<b>72</b>
<b>4.1 Design Standards</b>	<b>72</b>
Bluetooth Communication Standard	73
The Bluetooth Protocol Stack	73
I2C Communication Standard	73
Power Plug and Outlet Standard	74
Design Impact of Power Plug and Outlet Standard	75
Power Connector Standard	75
Design Impact of Power Connector Standard	75
IPC-2221, Generic Standard on Printed Board Design	76
Design Impact of IPC-2221	76
Light Emitting Diodes (LEDs)	76
Silicon Photodiode Standards	77
Photodiode Optical Radiation Standards	78
Photometer Standards	78
Photometer Design Impact	79



Passive Infrared Motion Sensor Standards	80
Passive Infrared Motion Sensor Design Impact	81
<b>4.2 Design Constraints</b>	<b>81</b>
Economic, Environmental, and Time	82
Ethical and Political	85
Social, Health, and Safety	85
Manufacturability and Sustainability	87
<b>5. Hardware and Software Design Details</b>	<b>90</b>
<b>5.1 Schematic of Window Design</b>	<b>90</b>
<b>5.2 Software Design</b>	<b>91</b>
Mobile App	91
The System Start Page	92
System Info Page	93
Brightness Settings Page	94
Privacy Settings Page	95
Schedule Settings Page	95
<b>5.3 Power Supply System</b>	<b>96</b>
5V Linear Voltage Regulator Circuit	96
3.3V Adjustable Voltage Regulator Circuit	97
Power Connector Circuit	100
<b>5.4 Motorized Polarizing Screen Mechanism</b>	<b>102</b>
Overview	102
Stepper Motor	103
Pulley and Polarizing Screen Adaptor	104
Belt and Pulley	105
Conclusion	106
<b>5.5 Motor System Design</b>	<b>106</b>
Motor System Breadboard Test	107
Circuit Design Breakdown	110
<b>5.6 Photodiode System Design</b>	<b>111</b>
Thorlabs - FDS1010 Specifications	113
Photodiode Circuit Schematic	115
<b>5.7 PIR Motion Sensor System Design</b>	<b>116</b>
AMN 34111 Alliedelec Specifications	118
<b>5.8 Overall Schematic &amp; PCB Layout</b>	<b>118</b>

<b>6. Project Prototype Construction and Coding</b>	<b>121</b>
<b>6.1 PCB Vendor &amp; Assembly</b>	<b>121</b>
<b>7. Project Prototype Testing Plan</b>	<b>124</b>
<b>7.1 Hardware Specific Testing</b>	<b>124</b>
PCB Testing	124
Motor System Testing	125
<b>8. Administrative Content</b>	<b>126</b>
<b>8.1 Project Budget</b>	<b>126</b>
Estimated Project Budget	127
Items Purchased	128
<b>8.2 Project Milestones and Timeline</b>	<b>129</b>

# 1. Executive Summary

This document discusses the motivation, goals, specifications, and deliverables of the Autonomous Smart Window that our group has chosen to design. It also details every aspect of the design process, including the research that was conducted, the constraints and limitations that must be taken into account, any related standards, all relevant technologies, the thought process behind each part selection, and some preliminary experimental data.

The motivation behind the Smart Window is to design a compact window unit that uniquely integrates a number of functionalities that can all be controlled by the user or autonomously. The primary features of the Smart Window are controllable variable tint, privacy option with variable window transparency, color-varying LED lighting, and a fully autonomous system that is capable of operating the window in various modes.

Some of the primary specifications of the window include the following: selectable light transmissivity between 5% and 40%, selectable transparency between 10% and 75%, lighting that supports 50+ colors and illuminates entire window uniformly, changes in window tint occur within 10 seconds, privacy screen turns on and off in less than 1 second, autonomous system controls and varies lighting, tinting, and privacy features in real time based on mode of operation and reacts to environmental changes within 30 seconds.

As expected, standards and constraints affect the design of the Smart Window. Some of the standards that have been taken into account relate to Bluetooth integration and communication, circuit communication, electrical power sources and power connectors, PCB design, LED operating frequencies, silicon photodiode detection and radiation, optical photometer measurements, and PIR detection. The most notable constraints stem from cost limitations, time constraints, incorporating a mechanical rotating system within the window unit, limited space to contain all electrical components, and designing a custom window unit.

Up to this point, all of the effort that our team has put forth has gone towards research, ordering parts, and preliminary component testing. When the finished product is completed, the deliverables that will be demonstrated are as follows. Every function of the window will be controllable from a mobile application. The UI of the application will allow the user to turn the privacy on and off, select the haze percentage of the privacy screen, turn the LEDs on and off, select the LED color(s), and select the tint level. The window unit will respond to each command within a few seconds. The application will also allow the user to put the window in autonomous operation, and the supported modes will be based on monitoring the surrounding environment and controlling the privacy screen and tint levels.

## 2. Project Description

This chapter discusses the overall idea of the project on many different levels. We first define the project by discussing the motivation of the device, and goals that we hope to achieve. We accomplish this by identifying the problem that is in need of solving, then we address the problem by proposing a solution that is complete and innovative. Next, we refine our solution by suggesting a way to implement our idea through the use of current technologies. We then move on to define all of the qualitative specifications, followed by a House of Quality analysis. Finally, we assign elements of the project to each group member, and we define the quantitative specifications and deliverables that the window will be expected to meet.

### 2.1. Project Motivation and Goals

The motivation behind the Autonomous Smart Window stems from the shortage of fully customizable window options that are currently available on the market. In addition to the aesthetic beauty of windows, there are economic features and security functions that have yet to be integrated simultaneously within a single window unit. The goal of the Autonomous Smart Window project is to identify and incorporate as many window features as possible within a single window unit, and to make the entire system customizable, fully interactive, controllable, and autonomous.

There are many window accessories available to consumers, each of which is designed to accomplish a specific goal. For example, if one wishes to limit the amount of light coming through their windows, this can be accomplished using curtains, blinds, tint films, stained glass, etc. The same applies if one wishes to have a privacy feature (blackout curtains, blackout tints, blinds, light scattering films, etc.). However, it is extremely difficult, if not impossible, to find a window or accessory that can accomplish more than one or two functionalities at the same time. With that being said, the primary goals of the Smart Window are as follows:

1. Provide the most visually appealing appearance possible, yet deliver a different aesthetic look than the typical window
2. Allow for full privacy at the click of a button, while maintaining a beautiful appearance
3. Contain a variable tint feature that can be controlled to select the amount of light being transmitted through the window; also be used to control the amount of transmitted heat radiation
4. Integrate each of the functions seamlessly through a fully autonomous system, which can be switched on or off

## 2.2. Proposal and Objectives

The primary design specification of the Autonomous Smart Window is to create a compact window unit that will house all of the optical and electrical components. In order to meet this requirement, each functionality of the Smart Window must be designed to be as space-efficient as possible. With that being said, each mechanism will be constructed using the smallest, thinnest, and lightest components possible.

To create the variable tint mechanism, we intend to utilize a series of linear polarizers. One polarizer will be stationary, and the other will be attached to a rotating axle; the non-stationary polarizer can then be rotated to allow any percentage of light through the window. Since rotating a polygonal window would be complicated and potentially problematic, we envision the Smart Window consisting of a circular dual-pane window unit. The privacy screen will not be built; it will instead be purchased and installed between the two panes. The screen is a simple light scattering film, and therefore will not require much engineering design to incorporate.

Another aesthetic feature that will be included is an RGB LED window lighting system. LED strips will be placed around the inside edges of the window, allowing for the user to select what color to make the window glow. This visual element will be useful for turning the window into a bright centerpiece of attention during night hours. A light collecting/redirecting film will be placed somewhere on or inside the window to allow for the propagation of the LED light across the entire window. Depending on the brightness and efficiency of the LED/film system, it may be possible to use it in tangent with the privacy screen during the day.

Finally, the Smart Window will contain PIR sensors and a photometer to allow the autonomous system to monitor and control the device. The PIR sensors will tell the system when to turn on the privacy screen, and the photometer will determine what tint level the window should be at.

## 2.3. Qualitative Specifications

Having identified the primary objectives and vision for our project, the next step is to begin specifying all of the functionalities that we want our device to have. Before we settle on definitive and quantitative specifications, we start with qualitative ones that provide a general idea of the intended outcomes that we hope to achieve. These qualitative specifications are helpful in making sure that each group member is on the same page when it comes to knowing exactly what our final product might look like and do. We cannot identify quantitative specifications until we first discuss and agree on each of the qualitative ones.

The specifications that we identified have been listed below; the specifications are organized based on what aspect of the Smart Window it pertains to.

## Window and Film Specifications

- Window will contain switchable light scattering film to provide instant privacy on demand
  - When turned on, window will appear frosted over, emitting a bright white hue
  - When turned off, window will be fully transparent
  - Will be contained within the dual-pane window (between the panes)
- Window will have colorful lighting options that can be customized and changed
  - RGB LED strips placed around the inside edges of the window will illuminate the entire inside face of the window, providing a bright, uniform glow
  - LEDs will be facing towards the center of the circular window, shining light across the glass window
  - Light collecting/redirecting film will be placed either within or outside the window to enhance the light propagation across the area of the window
  - Allow for the color to change on its own as a function of time (built-in presets)
  - If possible, make the color lighting bright enough to be operable during daytime (with privacy screen turned on)
- Variable tint mechanism will be built into the window's design
  - Makes use of two linear polarizers. One (or both) will rotate, changing the amount of light that is transmitted through the window
  - Polarizers must be mounted onto rotating axles (perhaps each pane will be embedded in an independent rotating bezel) with a motor connected to one or both of them
  - Allow for full control over the window transmittance level
  - If possible, utilize a third polarizer centered in-between the other two, containing an image or design. The image could be made to be dark with a transparent background or vice versa. This feature would require both linear polarizers to be rotatable
- Entire window will be designed to contain all features within a single, compact unit
  - Circularly shaped with a diameter between 12 in. and 14 in.
  - Design should allow for some kind of rotating capability
  - Window encasement should contain most, if not all, sensors, computers, and electrical components

- All films will be contained within or on the inside of the window

## Electrical and Computer Specifications

- The Window shall utilize 120V AC power utilizing wall outlets
- There shall be an AC-DC converter to power the controller and other electronic components
- The Window shall contain a power meter to measure power consumption
- The power used shall be kept at or below 3-5 watts per square-meter of glass
- The controller shall adjust the voltage of the power supply to control light transmission levels
- The Window shall contain a custom PCB
- The app will be used to configure the system with information such as window area, user light preference, and out of home hours

## Sensor Specifications and Descriptions

### *PIR Motion Sensor*

The customized window will allow for unrivaled privacy. It will use two custom built passive infra-red motion sensors. One will be placed facing the outside of the window unit while the second one will be placed facing the inside. The passive infrared motion sensors will detect human movement and relay the information back to the user, who will have the ability to set the window to immediately activate privacy mode if a person is within 8 meters of the window.

The passive infrared motion sensor will have the ability to detect any human moving in the detection zone at no greater than one meter per second. Finally the motion sensor must have the ability to operate in reasonable environments, therefore it must operate in temperatures ranging from zero degrees celsius up to 50 degrees celsius to ensure that it will function in most places around the globe. The passive infrared motion device will also allow for users to elect for privacy mode which gives the ability to frost the window if the owner is detected inside of the perimeter.

### *Optical Photometer*

The unit will come equipped with a miniature photometer. The photometer will be used to measure the intensity of light, in units of radiant flux, coming through the window before the light has been polarized. The surface area of the photometer

will be large enough to ensure that an accurate and precise reading of incident sunlight from larger angles can be gathered.

The photometer will also act as a radiometer as it must record wavelengths in both the ultraviolet spectrum and wavelengths in the near infrared spectrum. The photometer must also have a minimum amount of defects in the epitaxial layers to ensure lowest possible reverse bias voltage inputs. This will allow for maximum accuracy when recording the data as there will be only trace amounts of dark current present inside the photometer.

It will be custom built to be small enough so that it is barely visible to the user. The photometer will record its data and then relay the information to the arduino that controls the rotation of the polarizers. The user will be able to use this data to customize how much light they want to enter the window. The window will also come with a pre-built energy saving feature that will use the photometer readings to auto set the polarizer positions, blocking out sunlight and unwanted heat.

## 2.4. House of Quality Analysis

To identify which functional requirements we need to focus on, we built a house of quality diagram and inserted our predicted customer data. The results showed that the window & electronics integration is a key part of our design and cannot be removed. The other parts of the project we should focus on are the quality of the photometer to correctly measure the light, and the computing capability to handle all tasks. One of our least significant components is the led strips. Because they drain the battery and increase the cost of the unit without adding any functionality.



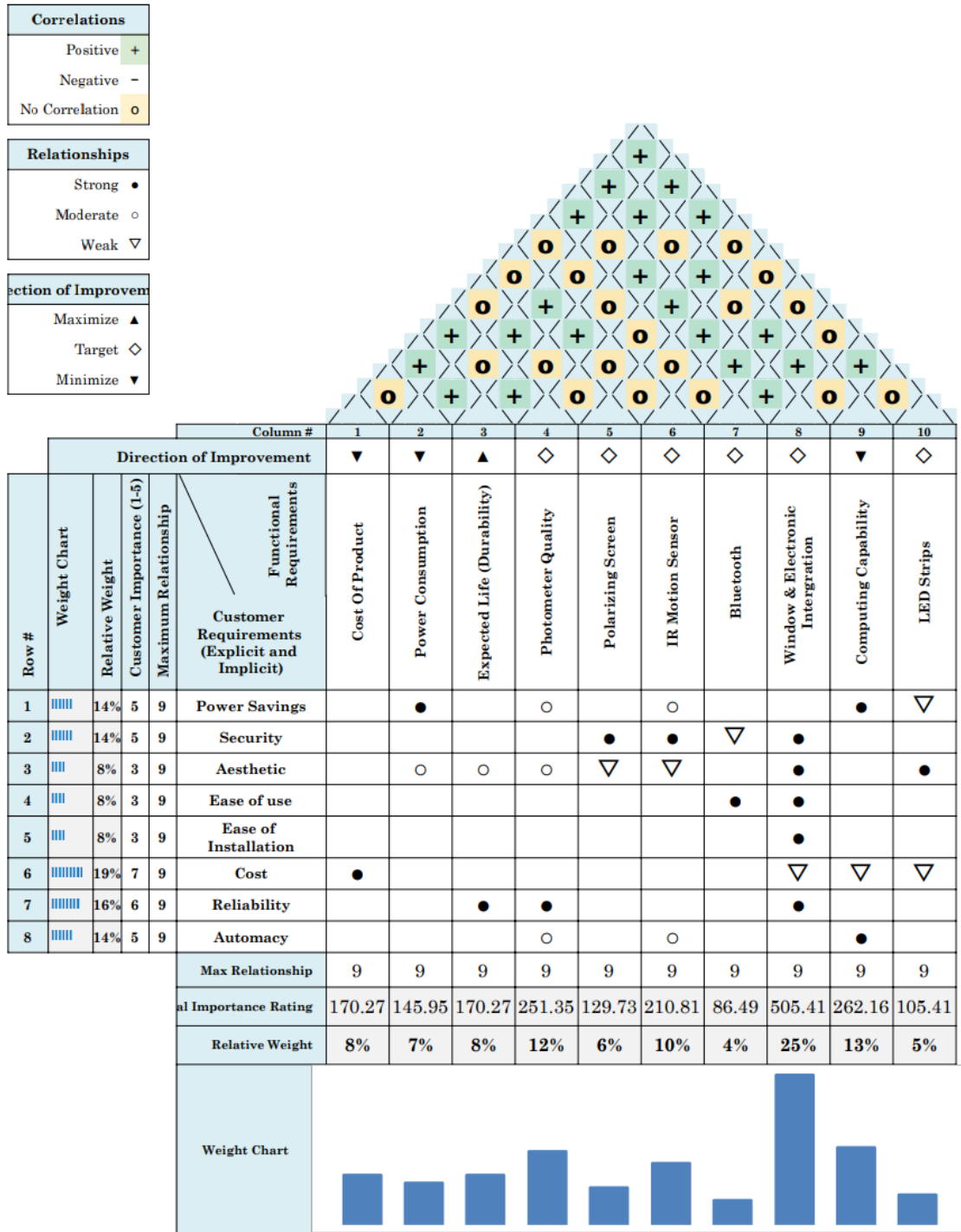

Figure 1 - House of Quality

## 2.5. Block Diagram

The block diagram shown in Figure 2 is meant to provide a visual representation of how the major components of the device will work in cohesion with each other to meet the end goals of our project. Each block is color coded to denote which group member is responsible for that portion of the project.

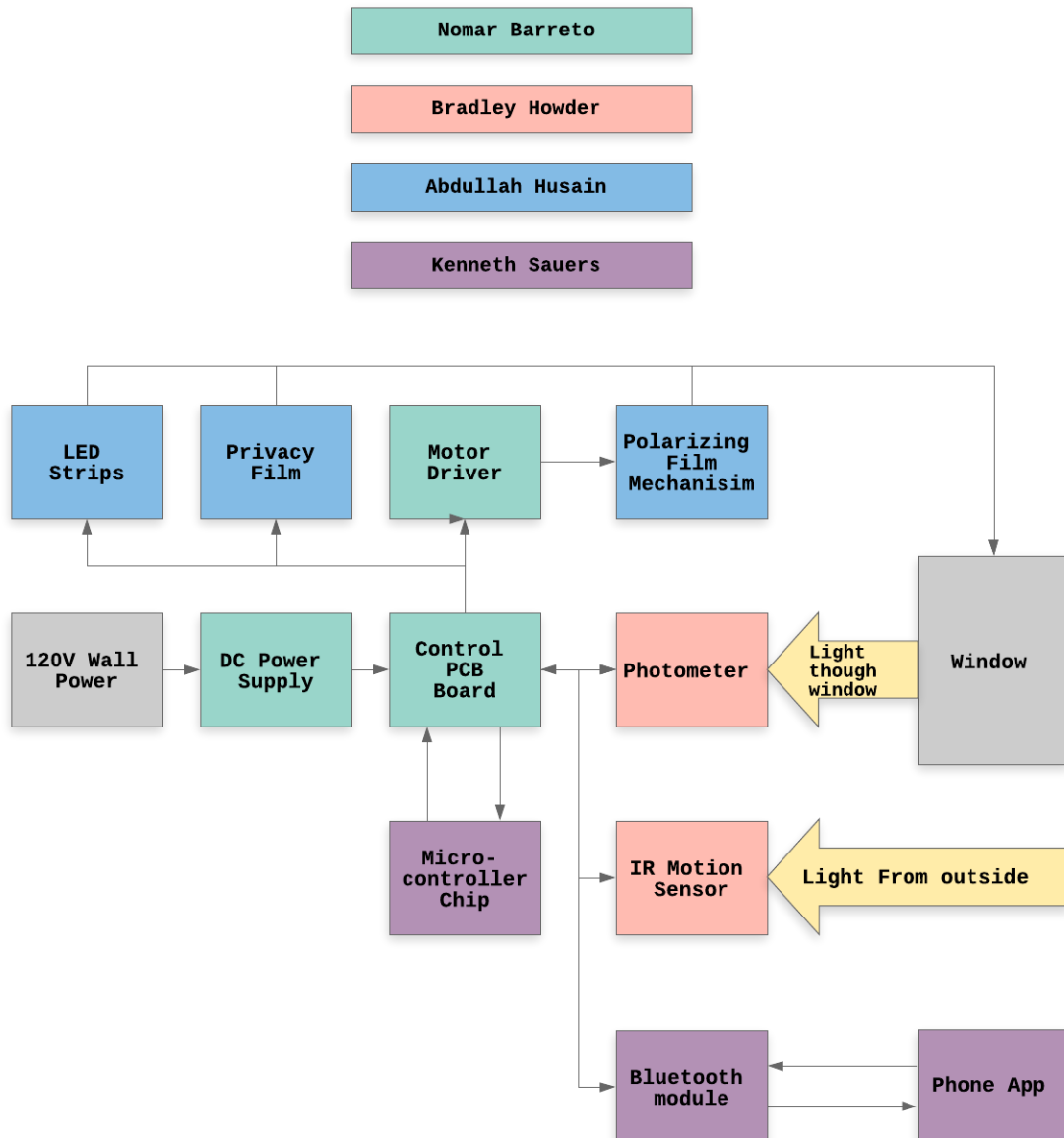

Figure 2 - Block diagram

## 2.6. Summary of Quantitative Specifications and Deliverables

The below table of specifications list the most simplistic objectives that we have come up with, and make up the foundation of our project. These are our most basic goals, and we expect to accomplish each of them. A more advanced iteration of our project would consist of the same base specifications, but would make use of waveplates in conjunction with polarizers in order to achieve variable tinting capabilities. The purpose for this would be to maximize the upper limit of the window's transmissibility. It may not be possible, but if we are able to put forth an attempt at incorporating it, we will do so.

Our advanced project also includes an option to include a single piece of polarizer artwork integrated within the series of polarizers, incorporated in such a way that the design could be made to allow light through it while the rest of the window is being tinted, or vice versa. Our most ambitious goal would be to construct the window with all of the previously mentioned functions, as well as a transparent display within the window. The display would present general information like the time and date, as well as all window-related information such as tint level, outside temperature, and the amount of heat being transferred through the window. In addition, we would make the display be visible in complete darkness via LED illumination.

In Section 2.3 we discuss the qualitative specifications of the project. In this section, we list out each component and the desirables that relate to the component. We also elaborate further on the specifications that relate to each component by quantitatively describing what we hope to achieve. All information is contained in Table 1.

Spec #	Component	Demonstrable Outcomes and Quantitative Specifications
1	Variable Tint	<ul style="list-style-type: none"> <li>● Light transmission at 40% in the “off” mode</li> <li>● Light transmission at 25% in the “energy saver” mode</li> <li>● Light transmission at 1-5% in the “sunblock” mode</li> <li>● Tinting takes effect in less than 10 seconds</li> </ul>
2	PIR Motion Sensor	<ul style="list-style-type: none"> <li>● Privacy screen turns on when movement detected in front of window up to 10m</li> <li>● Privacy screen turn on when movement detected behind window up to 10m</li> <li>● Phone alert when suspicious activity (loitering) detected outside of window</li> </ul>
3	Photometer	<ul style="list-style-type: none"> <li>● Light transmitted through window shown in app and updated regularly</li> <li>● Transmitted light shown to be 25% when tint mode is changed</li> <li>● Tint showed to be controlled by how much transmitted light is being read</li> </ul>
4	Single Compact Window Unit	<ul style="list-style-type: none"> <li>● Window panes will be no wider than 12 inches</li> <li>● Window frame will hide almost all electronic/mechanical features from the visible eye</li> <li>● Window will allow for placement of privacy screen,polarizers, LED's between panes of glass</li> </ul>
5	Phone App Integration	<ul style="list-style-type: none"> <li>● Android phone app integration</li> <li>● Controlled light transmission from phone</li> <li>● Controlled window color and privacy screen from phone</li> </ul>
6	Privacy Screen	<ul style="list-style-type: none"> <li>● Masks identity of user behind window</li> <li>● Ability to turn off when clear visibility is desired</li> <li>● PIR connectability to turn on when movement is detected</li> <li>● Dimmable to select anywhere within range of transparency of 10%-75%</li> <li>● Switches on/off and dims in less than 1 second</li> </ul>
7	LED Window Illuminator	<ul style="list-style-type: none"> <li>● Privacy screen will change color to user-selected color</li> <li>● Will have minimum 3 color modes RGB</li> <li>● Will be able to change intensity of light based on user needs</li> <li>● Will illuminate the entire window uniformly</li> </ul>

Table 1 - Summary of specifications and deliverables.

## 3. Project Research and Part Selection

This section discusses all of the details related to the research of the project. Up to this point, we know what the objectives and deliverables of our device are, and we have defined the problem that we hope to solve. The next phase of our project consists of researching the market for pre-existing solutions to our problem, as well as any products that are similar to the Smart Window that we hope to design. We are looking to verify the need for our device, as well as looking for the optimum way to achieve each functionality of our window.

To accomplish this, we scanned the market for all technologies relevant to our idea; anything that could potentially be utilized or incorporated into our own design was looked into and evaluated. Once each potential component was fully researched, we compared them all and went forward with the part selection process.

### 3.1. Similar Projects and Existing Products

Before settling on our project idea, we first researched the market to see what types of products already exist that accomplish the same goals as ours. We found many products, some of which we drew inspiration from. For starters, there are a few mainstream alternatives to our smart window, such as common household blinds and curtains. Blinds allow the user to adjust the amount of light entering through a window, and they also allow for total transmission through the window to allow for complete window transparency. Further, they can be set to block the entire window, providing complete privacy. In some cases, the “closed” mode may block out nearly all the incoming light, providing a “black out” feature. They come in different styles and colors, but all accomplish similar goals: they look decent (especially the textured and colored ones) and they do a good job of providing privacy and varying the amount of sunlight entering the room.

Curtains are sometimes used in tandem with blinds, and sometimes used on their own. The functionality of curtains vary based on what the consumer is looking for. Some can be used to block out all of the incoming light, allowing for complete privacy. Others can provide privacy but not necessarily block out much light, while others are not very good at blocking out light or providing privacy. Since curtains can be opened or closed, they do allow for some customizability. In general, however, they are primarily used for privacy, blocking out sunlight and heat, and adding a touch of beauty to one’s home.

Window films are another window accessory that can be quite useful for blocking out sunlight and heat, and they may even be used for privacy purposes. These tinted films are usually adhered to the window itself, and are typically set to block out a certain percentage of light. Some films, such as photochromic films,

automatically increase and decrease the amount of light that is transmitted through the window based on how much light is incident onto the film. In addition to photochromic films, colored films can also be used to beautify the window. However, the color is almost always constant and does not allow for variability.

There are other special preexisting windows that accomplish the same goals as window films, such as stained glass, glass bricks, textured glass, and smoked glass. Stained glass is usually brightly colored, providing a very decorative appearance while also supplying privacy and some sunlight filtering. Colored glass is an alternative to stained glass that does virtually the same things as stained glass. Glass bricks are unique in that they don't look like a window. They are stacked together like bricks to make up an entire window, and they can vary in transparency.

The thick glass within each brick is usually distorted or made to scatter the light, allowing for excellent privacy. Textured glass refers to glass panes that have been fabricated to contain patterns or textures within the glass itself. It is very decorative and can be great for privacy, but depending on the intricacy of the patterns, may be difficult to see through at all. Smoked glass looks almost like a clear glass pane with a tint film over it, but it usually has a bit of a diffused appearance to it. They are good for limiting light transmission through the glass, and the "smoked" finish helps slightly with privacy while still remaining transparent enough to see through. Frosted glass (or translucent glass) is similar to smoked glass, except frosted glass maintains a typical glass color as opposed to adopting a darkened color.

One window accessory that caught our eye during research was the Polymer Dispersed Liquid Crystal (PDLC) film. Often marketed as a light scattering privacy film, PDLC films are widely available, and are typically placed on or inside a window. They can be switched on and off simply by applying an electric voltage. When no voltage is applied all incident light is scattered, embellishing the window with a frosted white appearance across the entire window.

When a large enough voltage is applied, the window becomes fully transparent again. The switchability of these films is extremely attractive, which is why we elected to include this feature in our window design. There are many companies that sell custom sized windows and window films that incorporate PDLC technology. *Switchglass*, *Smart Tint*, *Rayno Window Film*, and *Invisishade* are some of the leaders in this space, although pre-cut PDLC films can be purchased from other online sellers such as *Amazon*.

Based on our research, windows with a variable tinting feature do not seem to be very popular or easily accessible through the Internet. After many hours of searching, we only found a couple applications of the type of variable tinting technology that we were seeking. Interestingly, both of the companies that we found were making use of the technology for automotive applications, the

companies being *Electric Auto Tint* and *Continental Automotive*. Unlike photochromic films, these companies have discovered a way to vary the amount of light transmission with the click of a button (or in *Continental's* case, autonomously), and they have a range of transmission percentages to choose from. Despite the amount of research we did, we found that it would be extremely difficult to get our hands on the same technology. However, our rotating polarizers should be able to achieve the exact same effect for a much more affordable price.

## 3.2. Relevant Technologies

Since the main functionalities of the device have been decided on, the project has been divided into corresponding branches. Each branch contributes to one or more of the important end goals of our project. These include the tinting mechanism, user interaction, computer integration, etc. Within each branch, we list and describe as many existing technologies that we may be able to use for that aspect of the Smart Window. We tried to be as comprehensive as possible, and we listed all of the relevant details of each technology as it pertains to our desired uses.

### Motion and Torque Transfer

In our project, in order to rotate the polarizing film we require a system to transfer the rotational motion from a motor to the polarizing film. The methods are discussed below.

#### *Gears*

Gears are rotating disks with teeth; the teeth interlock with the teeth of an adjacent gear to transfer rotational motion from one gear to another. The design of the teeth differentiate types of gears. Each one has advantages and drawbacks. The simplest to manufacture is the spur tooth gear, because the teeth project radially out from the center of the gear. A tool such as a plasma or laser cutter could be used. This is much easier than machining with a mill.

The next type is a helical gear. The teeth on a helical gear are rotated and not parallel to the shaft of the gear. The tips of the teeth form a helix around the shaft which is where they get their namesake. These gears are used in high speed gearboxes because of their reduced noise. The reduced noise comes at a cost of a higher cost to manufacture and higher friction between the teeth. The next type is worm and bevel gear. Both serve the same purpose of transferring rotational motion from one plane to an orthogonal plane. Using one of these gears would add to the total width of the window frame which we are trying to minimize.

## *Pulley and Belt*

A belt and pulley system transfer motions from one disk to another using a set of teeth. Unlike a gear, these teeth do not interlock from one pulley to another but to a belt which two or more pulleys interlock with. When the belt is interlocked with the pulleys, power can be sent through the disk, moving the belt which in turn moves the pulleys.

An advantage of this system is that two bodies that have their motion linked, do not need to be in close proximity to each other. This opens up the design allowing the rotational body to be in more desired locations that will lower the thickness of the system overall. When creating the belt that encircles the pulley one may be synthesized from a long length of belt then spliced together to form the belt of the desired circumference.

## *Sprocket and Chain*

Sprocket and chain is similar to pulley and belt, however, it uses a series of interlocking metal components rather than using a belt made from a rubbery plastic. These metal components are connected by a pin, which allows them to rotate on that axis. This allows the chain to bend much like a rope but only in one plane. These systems are used in high torque systems because the Sprocket and chain connection is much stronger than a pulley and belt, but at the cost of additional friction.

## Fabrication Techniques

### *3D Printing*

3D printing is an additive manufacturing method where layer by layer plastic is laid down in desired points. There are two types of 3D printing. The first type is Stereolithography, where an ultraviolet laser is shined on plastic resin. This cures that resin turning it from a liquid to a solid.

The second type is Fused Deposition Modeling, where plastic is melted and extruded on a surface where it cools and hardens. Both types of printed offers many types of materials with different properties. Some materials are high strength and can be used for gears while others are flexible. This wide variety of materials and the ability to manufacture any geometry, makes 3D printing a popular choice for prototyping.



## *Plasma Cutting*

Plasma cutting is used to cut sheets of metal of reasonably thin thickness (about an inch) to predefined geometric shapes. These planar geometric shapes can be folded in a metal press to form three-dimensional shapes. This is the cheapest and fastest way to fabricate metal parts. Many shapes cannot be created by folding a plane (ie. a circle). This drawback limits which shapes may be made by using this method.

## *Laser Cutting*

A laser cutter is similar to a plasma cutter in which a sheet of material is cut according to predefined geometry. The laser cutter projects a high power laser at the material usually wood or plastic. At that point on the material the laser vaporizes the material. This is how the laser cutter cuts the shapes. Laser cutters offer low cost fabrication on large work surfaces usually 2ft by 4ft. Unlike a 3D printer, which may have a print surface of a square foot. The drawback is the thickness of the material is very limited. At maximum, its thickness may be a fourth inch. Many designers cut multiple geometries from the material sheet and laminate them together to form thicker shapes.

## *CNC Mill*

A CNC (Computer Numerical Control) mill uses a router with interchangeable tool parts which moves in three planes to carve out material from a piece of stock. The material which can be cut from include plastics, aluminum, steel, and wood. A mill allows the most freedom when designing parts. The parts created are the strongest of the previously mentioned fabrication techniques at the cost of being the most expensive.

## User Interactions

In this section we will discuss the various methods a user might interact with the system. These methods range from using a mobile device to communicate with the smart window to a Liquid Crystal Display (LCD) to a button system physically mounted to the smart window. All of the user interactions have advantages and disadvantages, which are outlined in the sections below.

## *Wi-Fi*

A Wi-Fi breakout board has a relatively low cost compared to other methods but has a down side. Hosting a website on the chip may be demanding for the microprocessor, even without a database. Constantly sending response pages to the user while event driven is still resource intensive. Writing a beautiful website for the user to interact with will be difficult, if not impossible, when only writing firmware on an integrated chip. Scaling the chip to becoming a full-fledged computer (ie. Raspberry pi) will make a nice website possible but dramatically increase the cost per unit of the product

## *Bluetooth*

Using a low energy Bluetooth system would be efficient because of its power draw of 10mW at a bandwidth of 1Mbits. This bandwidth might be small for most applications but for our application it is ideal. As noted in our House of Quality diagram, we want to minimize computing power and communication bandwidth to save power.

## *ZigBee*

ZigBee is a unique communication protocol which was especially designed for Internet of Things or Smart Home devices which our product falls under. Multiple ZigBee devices form a mesh network, where a device will act as a routing device and a client. Unlike wifi, which consists of networking and client hardware, ZigBee has client hardware that acts as networking hardware (ie. routers and switches) for the mesh network. Typical ZigBees wireless range is small; however, when multiple ZigBee devices form a mesh network, the derived range is higher than each individual component. Due to Wi-Fi's wide adoption in the market, few hardware manufacturers have chosen ZigBee over Wi-Fi.

## *LCD and Buttons*

The Liquid Crystal Display (LCD) screen and interactive buttons offer a different approach than the previously stated methods. It has the benefit of now forcing the user to download or use some time of software on an external device; such as, an app for a Bluetooth app or a website for a Wi-Fi module. It also received a power saving boost because the LCD may be turned off when not in use, placing it in a dormant state. In this state, the screen may be turned on by clicking the interactable buttons, activating its interrupt trigger. The con of these options is an overall increased cost of the unit. The LCD screen and the buttons are more

expensive than a small Bluetooth or Wi-Fi breakout board. We will also need to modify the window case more to accommodate the LCD screen and buttons.

## Mobile Bluetooth Application

The mobile application will be responsible for all user interaction with the Smart window system. Its responsibilities will be as follows

- Editing the scheduling
- Manually enabling the privacy tint
- Changing all setting and configurations

### *Native Android Studio*

Writing native code entails programming in java or kotlin in the android developer SDK. This most traditional method is praised for its speed. Developing in native is a very intensive process. When using this development framework, the user must develop every component themselves rather than using a framework, where many functionalities are provided.

### *Flutter*

Flutter is a framework developed by google. It has the advantage of working on both android and IOS devices. Traditionally a developer would develop a native android app using android studio in java and a IOS app in swift. This framework has become big in industry because it simplifies the project. Flutter also includes many animated images which will aid in creating a beautiful app without spending much time on user interface optimization.

### *React Native*

React Native was developed by Facebook to achieve the speed of a native developed app with the looks and ease of development of a framework. It is well maintained being the second highest number of contributors on github, and is used by many large companies such as instagram, tesla, uber eats, and discord.

The application is written in java script and the app structure is as follows:

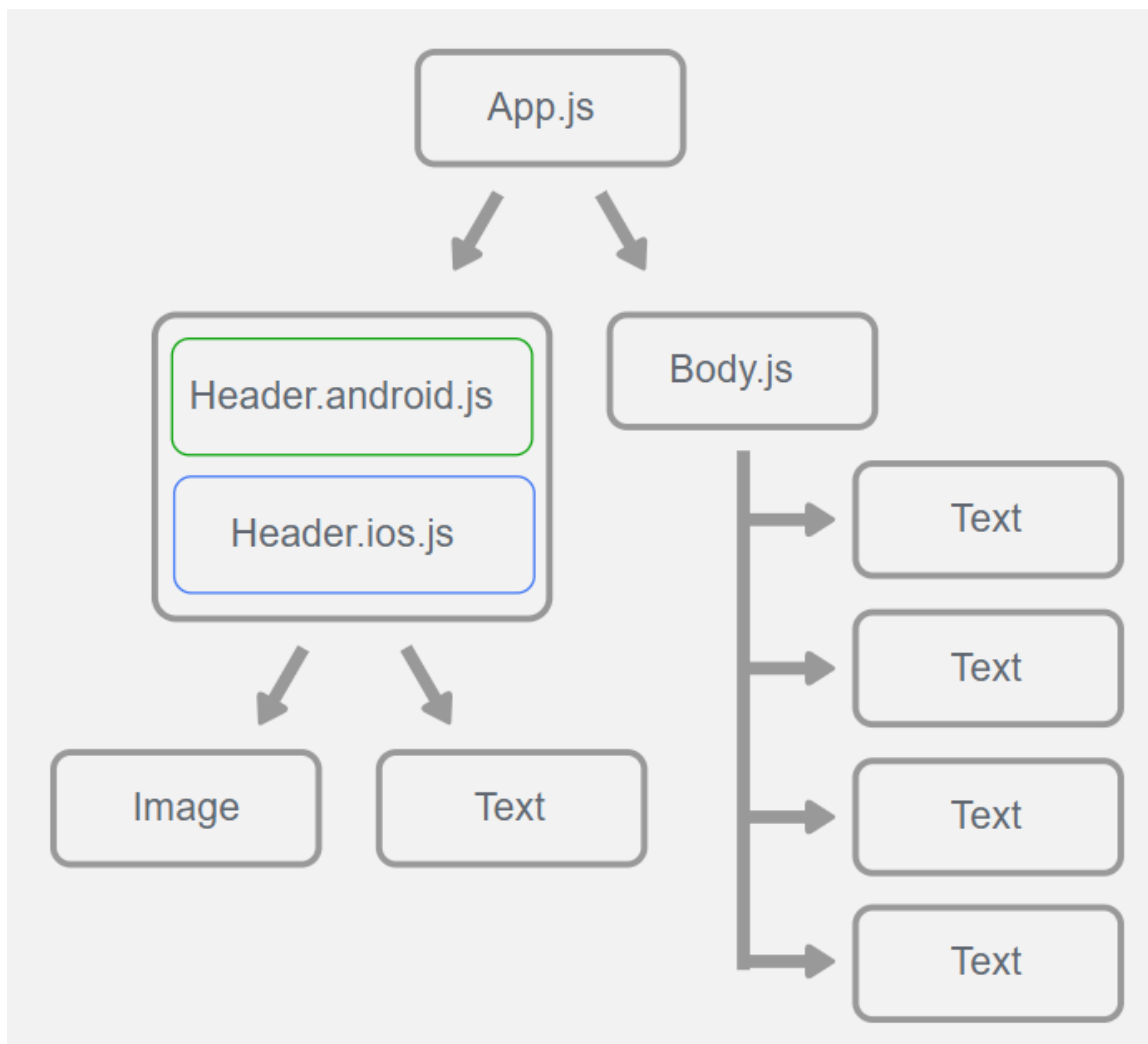

Figure 3 - React Native application structure (<https://reactnative.dev/>)

## Processor

### *ESP32 Breakout Board*

The ESP32 is a low power microprocessor with built in wifi and bluetooth capability. It can communicate on SPI, I2c, I2s, UART, CAM, Ethernet, and more. It can generate PWM signals on 16 of its GPIO pins for the motor driver. This processor is a 32bit dual core Xtensa clocked at 160-240MHz. The board has a self contained bluetooth module, two cores (one to process the photometer, and the other for all other calculations), and only costs \$9. All of these reasons would make the perfect processor for this project.

## *Texas Instruments MSP430G2553*

The MSP430 board is the smallest (2 ½cm in height, 1 cm in length) out of its competitors as well as the cheapest at 8 dollars. The drawback is that the program must be flashed to the chip which requires additional hardware to be purchased. Its processing power is the weakest out of all of its competitors but should just be enough.

## *Arduino Nano*

The Arduino Nano is a low cost (\$9) microcontroller. It has the ability to communicate through the i2c, SPI, and serial. It has 5 volt and 3.3 volt output pins. These can be useful to power other components without the need for a stand alone voltage step down circuit. It has a maximum of 19 digital and 7 analog GPIO pins. Two of its digital GPIO pins can be used for interrupts.

## *Raspberrypi*

The Raspberrypi is a very capable micro-computing platform. For the cost of ~\$45, the raspberrypi uses a SD card booted with a linux distro to operate. The Raspberrypi is a fully functional computer with an operating system. It constans 5 volt and 3.3 volt pins. It has 30 GPIO pins and can communicate in the i2c and serial. This will be overkill for the project, as far as processing power requirements needed the system would need to constantly host a bluetooth hotspot, run the photometer sensor, the PIR motion sensor, and handle scheduling.

## Power Supply

### *Batteries*

Batteries are a type of DC power supply and they come in two types: non-rechargeable and rechargeable. Non-rechargeable batteries can only be used once and these batteries include alkaline batteries and coin cell batteries. Rechargeable batteries include: lead-acid batteries used in cars, Ni-Cd batteries, Ni-MH batteries, Li-ion batteries which have the potential to explode if the terminals are short circuited, and Li-Po batteries.

The main advantage of using batteries for the smart window would be that they allow for portability of the window and that they are easy to replace. Batteries also have the advantage that they can be placed in series or parallel which allows for an easy adjustment to the voltage provided to the window.

The disadvantages of these batteries is that the batteries deplete quickly and need to be changed periodically. They also can be dangerous if they explode and for a window inside a house or business this could be disastrous. The smart window also does not need to be portable because it will stay in a fixed place permanently so batteries are not the ideal choice for powering it.

### *AC-DC Wall Adapter*

Also known as “wall warts” this power supply takes in the 120V or 220V AC voltage coming from a wall outlet and transforms it into a DC voltage at a lower value. There is also the choice of picking an unregulated wall adapter or a regulated one. The unregulated wall adapter might deliver a fluctuating output voltage that depends on the amount of current that the load connected draws which is a negative but unregulated wall adapters are simple and inexpensive. Regulated wall adapters deliver a consistent output voltage regardless of how much current the load draws making them good for applications where delicate electronics are used but they are more costly.

Using a wall adapter has the benefit that the smart window will be powered constantly and no replacements will have to be made. However the DC voltage obtained from the adapter might not be the correct one needed for all of the other electronic components in the window so a linear voltage regulator may have to be used to step down the voltage to a lower value. A buck-converter can also be used for the same purpose. A boost converter can be used if the desired voltage needed is higher.

To ensure compatibility between the adapter and the device, the adapter output voltage must match the rated input voltage of the device. The most common DC output voltages for these adapters are: 18V, 12V, 9V, 6V, 5V, and 3V. The adapter output current must be larger than or equal to the device’s rated current. Also the polarity of the barrel plug from the adapter must match the polarity of the port where the plug will be connected.

Barrel connectors have an inner cylinder and an outer one and these two have opposite charges. Barrel plug connectors most commonly have a center positive (+) configuration where the center is positive and the exterior is negative but a center negative (-) configuration also exists but is less common. The inner diameter of the plug and the outer diameter must also match those of the device to which it will be connected to.

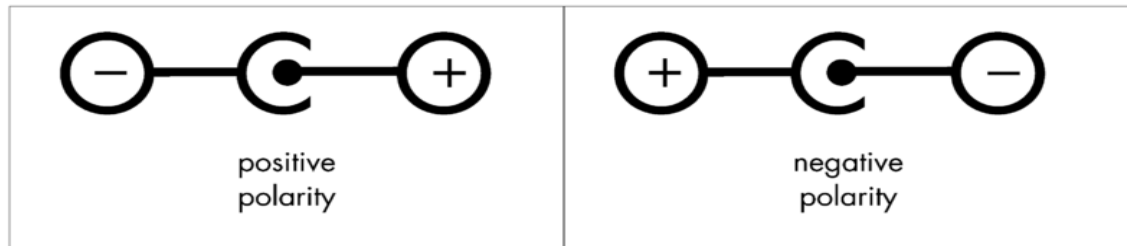

Figure 4 - Example of Polarity Diagrams for AC Adaptors (Image taken from [learn.sparkfun.com](http://learn.sparkfun.com))

## *USB Cable*

Universal Serial Bus (USB) is a common interface used to connect peripheral devices to personal computers. The USB interface connects two devices and allows one to be the host and the other to be the peripheral device. This interface can be used not only for the transfer of data but also for supplying power to other devices.

The advantages of using a USB cable are that USB cables are easy to use because you just need the cable and most computers have a USB port already installed in them. Also the USB device driver from the peripheral only needs to be installed once and after that, the driver will be automatically loaded to configure the device.

There also exist AC to USB adapters making it even easier to use them for the smart window. USB cables also double as DC power supplies and can supply 5V DC and they can also deliver up to 500mA of current if USB 1.0 and USB 2.0 are used. If USB 3.0 is used then up to 900mA of current can be delivered. USB cables also consume very little power and are inexpensive to buy. A severe disadvantage of using a USB cable is the distance limitation of the cable. The cable according to USB standards can be no longer than 5m or else a purchase of USB hubs will be required making the use of a USB cable more costly.

## Rotating Mechanism

### *Motor Driver*

To be able to control a set of motors to allow for the mechanical rotation of the window using the PCB board, we will need to use a motor driver module. The function of motor drivers is to obtain a low-current signal from a controller which

in our case will be either the PCB board or the microcontroller and then transform that current to a higher value essentially acting as a current amplifier. This is done in order to drive motors which require a high current input to start rotating because using a smaller current than the one rated for the motor can damage them.

There are certain specifications that must be looked at to pick the right motor driver for the smart window project and these include: maximum supply voltage, maximum output current, power dissipation, load voltage, the number of outputs which will be the number of motors that can be used using this motor driver, and the packaging type of the motor driver.

There are different types of motor driver circuits that can be used for the smart window project. One of them is a circuit that uses a transistor, a motor, a resistor, a diode, and an external DC voltage source to operate. When a large enough input voltage is applied to the base of the transistor then the motor will start rotating but if the input voltage applied is zero, then the motor will stop. This circuit allows for the rotation of a single motor in only one direction and is not practical when a motor needs to rotate in both directions, however an advantage of this circuit is the reduced cost because only five components are required to operate it.

A more common circuit that can be used is the H Bridge circuit. This type of circuit allows DC motors to rotate in both the forward direction and the reverse direction by changing the polarity of the input voltage. A typical H Bridge circuit will contain four switches and the motor will be in the middle of the H figure arrangement. A voltage source will be at the top of the H Bridge. At any time only two of the switches of the H Bridge circuit will be closed allowing current to flow through the motor in one direction. If the voltage source changes polarity, then the other two switches will be closed and the ones that were closed previously will open allowing current to flow through the other side of the motor driver circuit causing it to rotate in the opposite direction.

Typical components used for the switches can be Bipolar Junction Transistors (BJTs), relays or Metal Oxide Semiconductor Field Effect Transistors (MOSFETs). The advantage of using a circuit like this one is that the DC motor is allowed to rotate in both directions and not just one. The main disadvantage of using this circuit is that there are more components to it because four transistors or mosfets need to be purchased as well as the motor, and many diodes as well in more complex designs along with the DC voltage source.



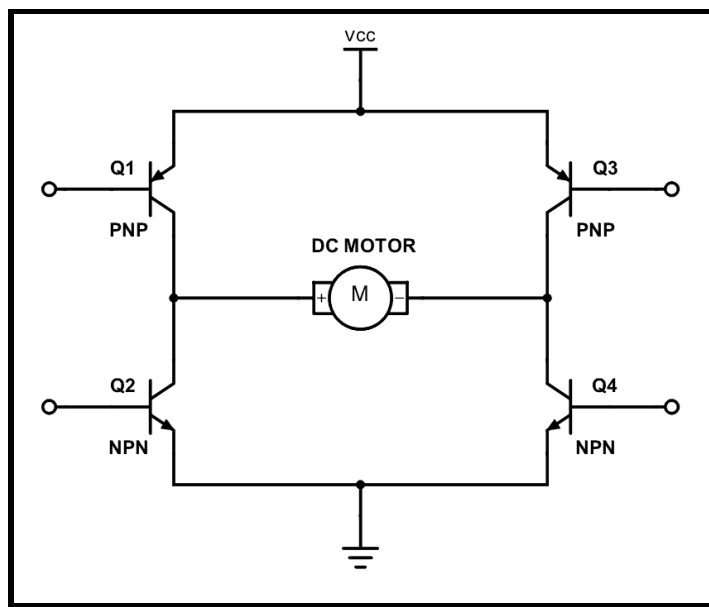

Figure 5 - Simple H Bridge Circuit (Image taken from Google.com)

The H Bridge circuit can be purchased in the form of an integrated circuit in order for the user to make their own connections or it can be purchased in the form of a motor driver module that only requires the user to connect the power supply to it and the motors. Most motor driver modules also allow for the connection of at least two motors rather than just one and they can be interfaced with microcontrollers such as Arduino which also allow for the control of the speed of the motors using pulse width modulated signals (PWM).

## Types of Motors

In order to use a motor driver to rotate the window the correct motors had to be chosen for the smart window project. The motors are going to be connected to the window and when a user uses the smartphone app to change the tint settings then the motor driver will talk to the motors and they will rotate the polarizers in order to achieve the tinting. Various types of motors were looked at but the main three motors most commonly used were the one analyzed for this project and they are: DC motors, stepper motors, and servo motors.

### *DC Motors*

DC motors come in both brushed and brushless varieties and are the most common types of DC motors. Brushed DC motors provide current to two stationary metal brushes and consist of coils around a component called a commutator which is the piece that rotates. The coils are surrounded by pairs of

magnets which are stationary and are called a stator and as the commutator rotates the brushes make contact with the commutator ring and a force becomes induced in the coils of the motor which causes it to rotate. The direction of rotation can be changed by reversing the polarity of the motor contacts.

Brushed DC motors have several advantages of which one includes being simple to control because a voltage can be applied to the terminals of the motor and it will start to spin. Lowering the voltage will cause them to slow down and increasing the voltage will make them go faster. Brushed DC motors also can achieve high torque at low speed and have efficiencies of around 75-80%. They are also very inexpensive but the drawbacks are that loud noise is generated from the DC motors as well as electromagnetic noise which could interfere with other components in the system. Also the brushes in the brushed motors can easily wear out over time and have to be replaced often and they also generate heat as a result.

Brushless DC motors on the other hand only have one moving component which is the rotor and the brushes from before are eliminated. The rotor for this motor is made up of permanent magnets and the coils are stationary. The advantages of using brushless DC motors are that they are more quieter than their brushed counterparts and generate less noise because there are no brushes, Brushless motors are also more efficient than brushed motors because they can operate at their maximum rotational torque versus brushed motors which only can achieve max torque at certain portions of their rotation. Brushless motors are also more durable because no replacement of brushes is needed. The disadvantage of brushless motors is that they are in general harder to control and require a controller.

## *Stepper Motors*

Stepper motors on the other hand are motors that offer precise position control because they move in slow precise steps and do not operate constantly like DC motors do. For stepper motors the only moving part is also the rotor which contains permanent magnets and the windings of the stator are surrounding it.

The polarity of each coil is controlled by an alternating current and as the polarity of the current changes each coil has a force applied on it causing it to move. Stepper motors can be controlled with microcontrollers but they constantly draw their maximum current and consume lots of power. Another disadvantage of stepper motors is that they have a low top speed and when the motor is moving, steps can be skipped when high loads are applied.

There are several ways to drive a stepper motor and one of these ways is called Wave Driver or Single-Coil Excitation. In this mode only one coil is activated at a time so for a 4-coil motor the motor will finish a full cycle in 4 steps of the motor.

A Single-Coil Excitation configuration is shown below where each coil only has a pulse at every 4 steps.

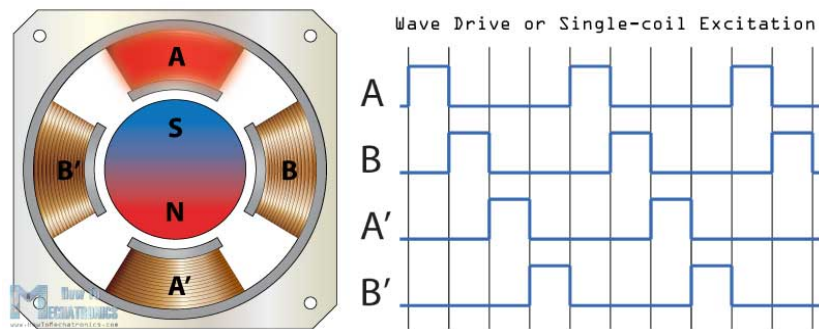

Figure 6 - Stepper Motor Single-Coil Excitation Mode Image taken from (<https://howtomechatronics.com>)

Alternatively, another stepper motor mode is the Full Step Drive mode which activates two coils at a time and provides a higher torque output however a motor with 4 coils for example will still make a full cycle in 4 steps anyway. The Half Step Drive mode improves upon the last two modes by having one active coil followed by 2 more active coils and a 4 coil motor will now complete a full cycle in 8 steps so there is more precision in using this mode.

However the most common method of controlling stepper motors is by using Microstepping which involves providing a variable controlled current in the form of a sine wave. Using this method increases the accuracy of the stepper motor and allows the motor to make a smoother transition between steps and stress on the parts of the motors is reduced. The use of Microstepping can be seen in the image below.

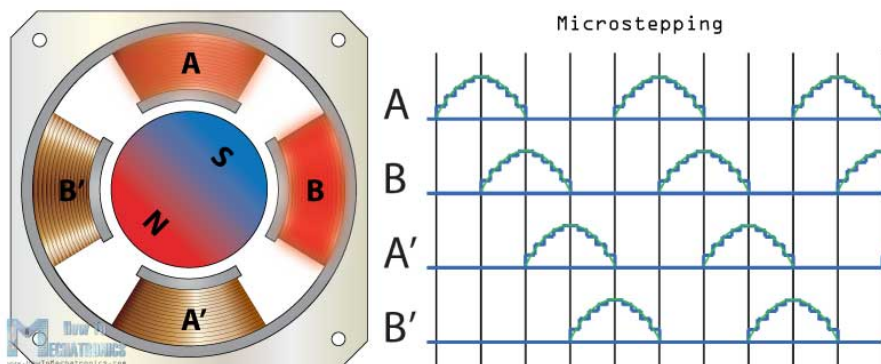

Figure 7 - Stepper Motor Microstepping Image taken from (<https://howtomechatronics.com>)

Another point to mention about stepper motors is that there are three types: permanent magnet stepper, variable reluctance stepper, and the hybrid synchronous stepper. The permanent magnet stepper motor has a permanent magnet as the rotor and is driven by the stator windings which have opposite poles causing it to rotate. The variable reluctance stepper motor uses a non-magnetized soft iron rotor with teeth in such a way that the rotor moves to minimize the space between the rotor teeth and the stator.

The hybrid synchronous stepper combines the characteristics of both the permanent magnet stepper and the variable reluctance stepper motors. It has a rotor made of a permanent magnet but it also has teeth and the stator also has teeth. The rotor however has two sections with opposite polarities and the teeth for both of these sections are offset from one another.

The advantages of using stepper motors is that they allow for precise positioning as mentioned before and usually have a high pole count and can move between them very accurately. They also allow for high speed control and can produce maximum torque at low speeds and can maintain their position very well. They are also easy to control.

However, disadvantages are that stepper motors generate lots of noise when they are working and at high speeds they have less torque than at low speeds and need an extra driver to achieve high torque at high speeds. They are also inefficient and get hot quickly due to the high current consumption mentioned before.

## *Servo Motors*

Servo motors are also good motors for when precise motion control is required. Servos usually consist of a DC motor, a potentiometer, and a control circuit. As the motor rotates the potentiometer's resistance changes and the feedback in the system can calculate the difference between the actual and desired speed or position and the controller can adjust the output to correct any error. When the motor shaft is at the correct position that is desired the power that is supplied to the motor will stop but if not then the motor will be turned in the proper direction.

The desired position is sent to the control circuit via electrical pulses through a signal wire. If the motor is close to the desired position, then the servo motor will turn slowly but if it is far away from the desired position, then the motor will turn quickly. This method of moving the servo motor is called proportional control because the motor's speed is proportional to the difference between the desired and actual positions so the motor will only move as fast as it needs to in order to achieve a task.

There are two types of servo motors namely AC and DC servo motors. The AC servos can handle high current surges and are suited for industrial applications while the DC servos are less expensive and can be used for smaller applications. There also exist servos that can perform continuous rotation rather than just rotating for small increments but they are not as common as the positional rotational servos which rotate within 180 degrees and cannot provide speed control.

Servo motors can be controlled by sending a pulse width modulation (PWM) signal which is usually a rectangular wave with a certain duty cycle meaning it is on for only a certain amount of time and then off for the rest of the time and there exists a minimum pulse as well as a maximum pulse and a repetition rate. The width of the PWM signal determines by how much the servo motor will rotate and it is common for servo motors to only be able to rotate by either 90 degrees or 180 degrees when the max pulse is sent as shown in the figure below which shows the PWM pulses sent to a servo motor and the direction and angle of rotation of a servo motor for each PWM pulse.

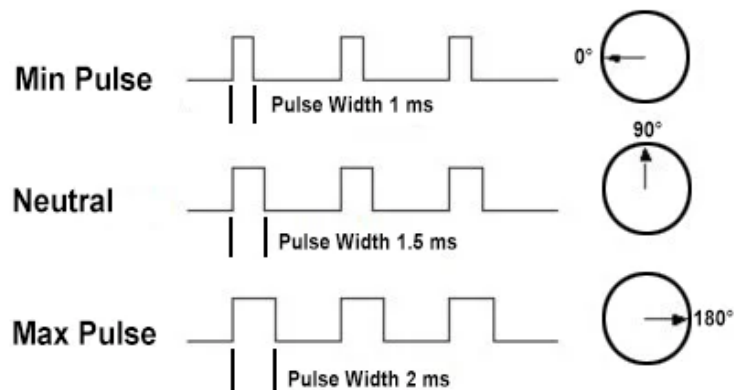

Figure 8 - Pulse Width Modulation (PWM) effect on Servo Motor Rotation Angle  
Image Taken from (jameco.com)

The advantages of servo motors are that they can achieve very high peak torques at higher speeds greater than 2000rpm and are very well suited for high speed applications because they use a closed loop feedback mechanism. Servo motors are also generally inexpensive and cost only a few dollars because the gears inside can be made of plastic which is cheap. There also is a large variety of servo motors in different sizes and with lots of torque ratings for many applications.

The drawbacks of servo motors are that positional rotation servos are limited in their range of motion because they can only move up to 180 degrees but not more than that. Servos also experience lots of jitter when their feedback

mechanism tries to constantly correct any difference between the desired and actual position of the motor so lots of twitching of the motor results when the servo is trying to hold a position and not move.

Below is a table comparing the different motor types considered for the smart window and the characteristics on which they were compared and the chosen motor type was highlighted.

	Brushed DC Motor	Brushless DC motor	<b>Stepper Motor</b>	Servo Motor
Torque	High at Low Speeds	High	<b>High at Low Speeds</b>	High at High Speeds
Noise Generation	High	Low	<b>High</b>	High
Maintenance	High	Low	<b>Low</b>	Low
Efficiency	Moderately High	High	<b>Low</b>	High
Precise Speed Control	Yes	Yes	<b>Yes</b>	Yes
Precise Rotation	No	No	<b>Yes</b>	Yes
Max Angle of Rotation	360°	360°	<b>360°</b>	180°
Cost	Low	High	<b>Low</b>	Low

Table 2 - Motor Type Comparisons

The type of motor that was then chosen for the smart window project using the table above was the stepper motor. The main reasons for choosing it were for its ability to produce a high torque at low speeds and for being able to provide precise control for the rotation of the window.

Stepper motors typically can have 50 poles all the way to 100 poles which allows the window to turn in small increments from pole to pole. It also has a low cost compared to other motors such as the brushless DC motor and it supports the 360 degree rotation needed versus another motor like the servo which cannot

rotate as much. The only two drawbacks are the amount of noise and the low efficiency but the pros outweigh the cons of the stepper motor and a little bit of noise can be tolerated in most cases.

## Tinting Mechanism

### *Photochromic Film*

In order to achieve a variable tinting feature, one option is to apply a photochromic film to the window. Photochromic films are transparent and tinted, but the darkness of the tint varies based on the amount of light incident onto the film. Under very bright conditions, the tint would be darkened. When the incident light is decreased, the tint subsides.

Photochromic films allow for a wide range of light transmission. However this transmission is not controlled by the user, instead it is an automatic feature of the film itself. By being an automatic feature this allows for the window to be more energy efficient at the cost of user customizability.



Figure 9 - Example of photochromic film under various lighting conditions (Image taken from Amazon)

Figure 9 represents how photochromic films function. As shown moving throughout the day the tint begins with nearly no polarizing features but as the incident light becomes more direct on the film as shown in the third window labeled “noon” the tint will darken to it’s maximum polarizing capability.

### *Electrically Controlled Blinds*

Another option would be to use electrically controlled blinds or shades. These devices are usually motorized, and are useful for incrementally varying the amount of light entering through a window. Additionally, they provide an added degree of privacy when closed fully. On the downside, they usually cannot block out 100% of the light, and they would be difficult to integrate into a window unit since they are usually designed to be installed within a windowsill.



## Rotating Polarizers

A system of linear polarizers can be placed atop one another, then rotated to vary the amount of light shone through them. The amount of light allowed through the system can be altered very precisely simply by rotating one of the polarizers a very small amount. One downside to this alternative is that the polarizers and the window itself would need to be circular in order to allow for seamless rotation. Another downside is that we would need to construct our window in a way that allows for the rotation of the polarizers, which will most likely require the implementation of a mechanical system.

Perhaps the biggest drawback is that linear polarizers cannot achieve light transmission greater than 50% for sunlight. For this reason, we may explore waveplates to try and increase transmission levels. An added pro is that this method can achieve 0% light transmission, providing an extra layer of privacy to the window.

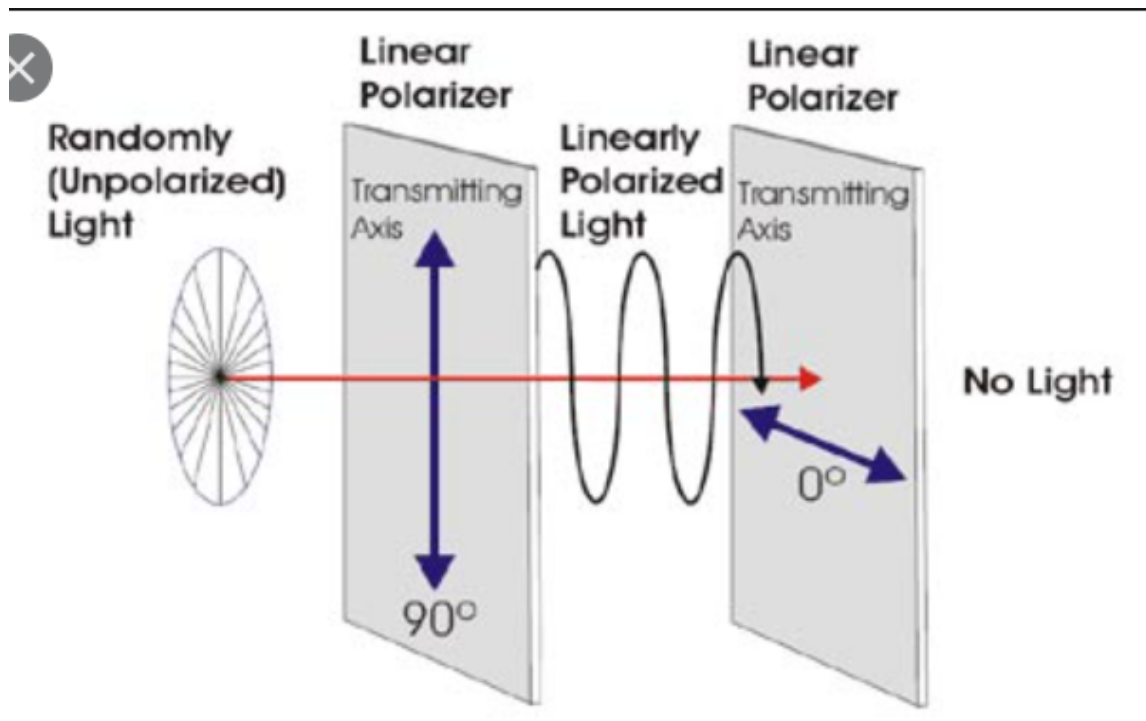

Figure 10 - Image showing how unpolarized (sunlight) incidents on the first polarizer and is blocked by the second polarizer (Image taken from Japanistry.com)

Birefringent polarizers are another option for polarizers that can be used to customize the transmission of incoming sunlight. They work by using the refraction properties of different types of crystal to separate incident light into two distinct rays, the extraordinary ray and the ordinary ray. These rays take two slightly different paths one of which can be blocked out. The incident light transmitted through the polarizer can be changed based on the angle that it is received at.

However angling the polarizer inside a window can be very difficult to achieve. Even if the polarizer is angled correctly at a time, when the earth spins and the sun moves through the sky the angle of light incident on the polarizer will be thrown off. This would require additional equipment inside the window to constantly move the polarizer to ensure optimum incident angle throughout the entire day. The crystal birefringent polarizers are also much thicker than linear polarizers making it challenging to fit in between a dual pane window.

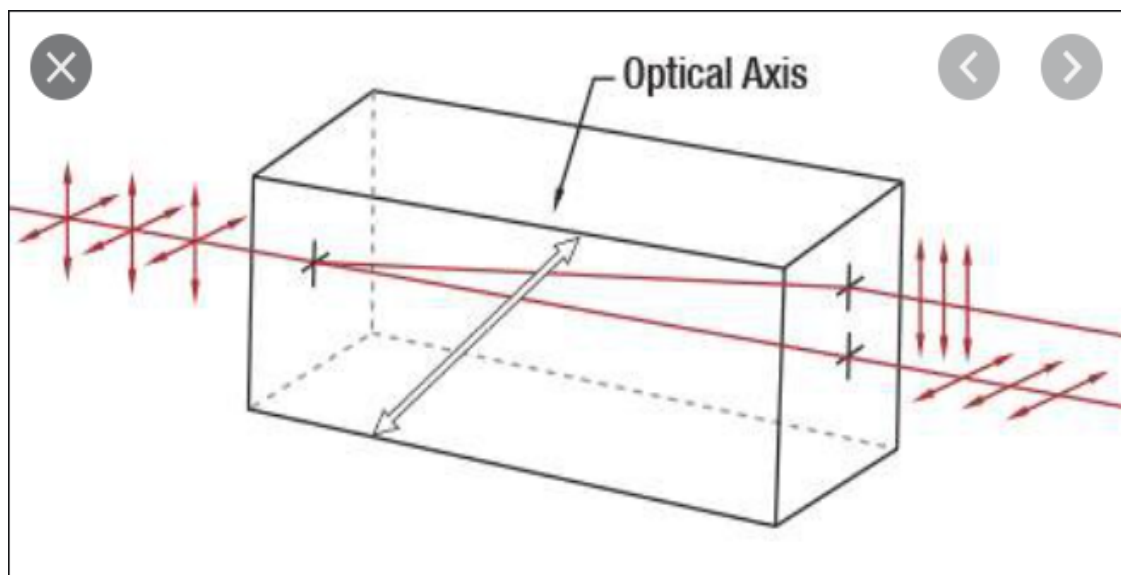

Figure 11 - How a birefringent crystal separates incident light into two separately polarized rays (Image taken from S and R optics)

Figure 11 represents how a birefringent polarizer functions. As shown when the light is incident at the correct angle the light will be separated based on its transverse component and its longitudinal component represented by the arrows on the far right of the figure.

## Privacy Screen

### *Reflective Polarizer*

There are many methods that could be used to provide a privacy feature for our window. One idea is to use a reflective polarizer on the outside of the window. This idea would only be feasible if used in conjunction with the rotating polarizer tinting scheme. The reflective polarizer would act similarly to a one-way mirror in that it would only be transparent for a viewer on the inside looking out. The downside to this is it cannot be switched off, therefore the window would always be in privacy mode, disallowing outsiders from ever seeing inside the home.

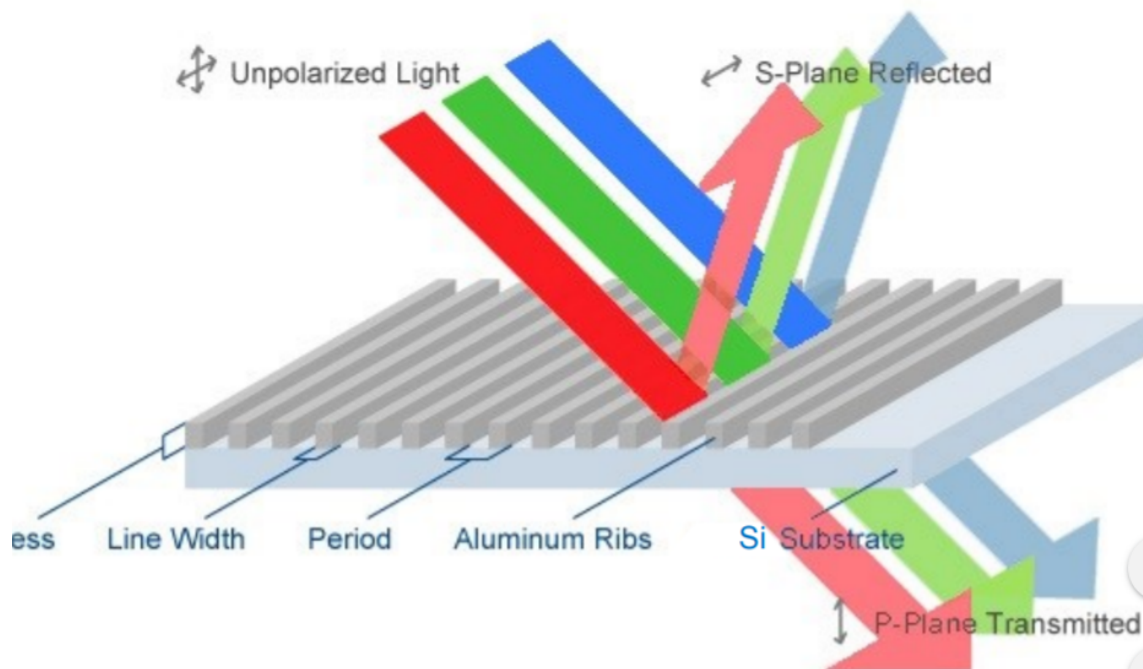

Figure 12 - How light is reflected off of a window to achieve privacy (Image taken from moxtech.com)

### *PDLC Film*

Another flexible option would be to use a Polymer Dispersed Liquid Crystal (PDLC) film. These films can be placed onto the window, and they use an electric current to switch the film back and forth between privacy mode and transparent mode. When no current is applied, the film is in privacy mode, and all the incident light is scattered. This causes the entire film to glow a frosted white color, which is very visually appealing. But more importantly, it prevents anyone from seeing through the window no matter what side they are on.

This two-sided privacy is not as ideal as the reflective polarizer's one-way mirror effect, but it does allow for a great visual effect that can be observed from the inside of the window. The primary pro of this technology is that it is switchable, and it can be switched from one mode to another within a few seconds. Dimmable PDLC films also exist, which allow the user to vary the cloudiness and

transparency of the film. This is accomplished by varying the amount of voltage applied to the film.

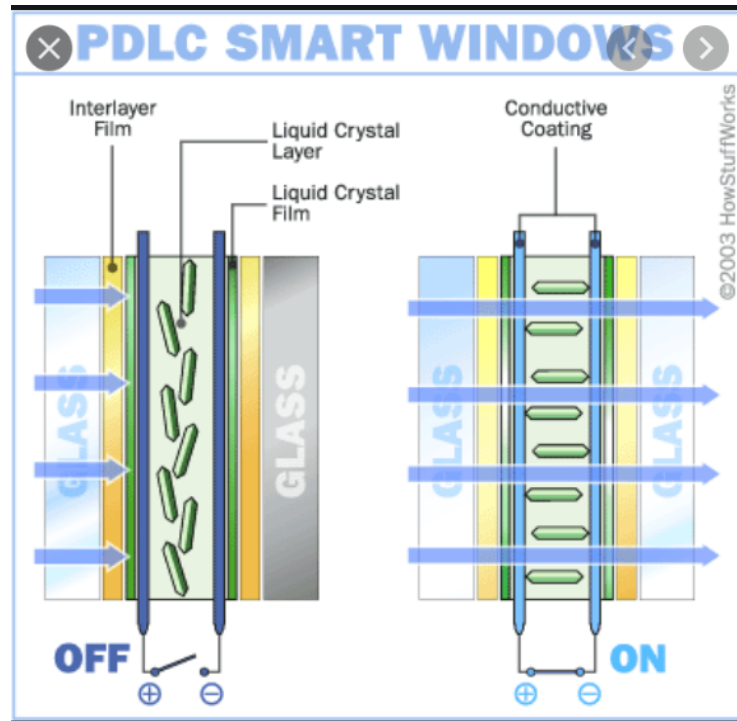

Figure 13 - Image showing how PDLC film works to scatter incoming light (Image taken from Dashdoor.com)

Figure 13 represents how a PDLC smart window functions. As shown in the leftmost image when no current is run through the film, the layer labeled "liquid crystal layer" is scattered, the light will incident on the crystals in these layers and diffuse across the length of the glass. This diffusion of light causes the film to become opaque preventing human eyes from seeing through the film.

The image on the right shows how the film functions when a current is being run through the film. The "conductive coating" as labeled in the image provides the conductive material for current to run through both sides of the film. Now in the section that was labeled the "liquid crystal layer" the crystals align themselves in perfect rows horizontal to the incoming incident light. The light will no longer be diffused through the crystals and as the blue arrows suggest the light will pass right through the glass allowing for people on either side of the window to see in or out.

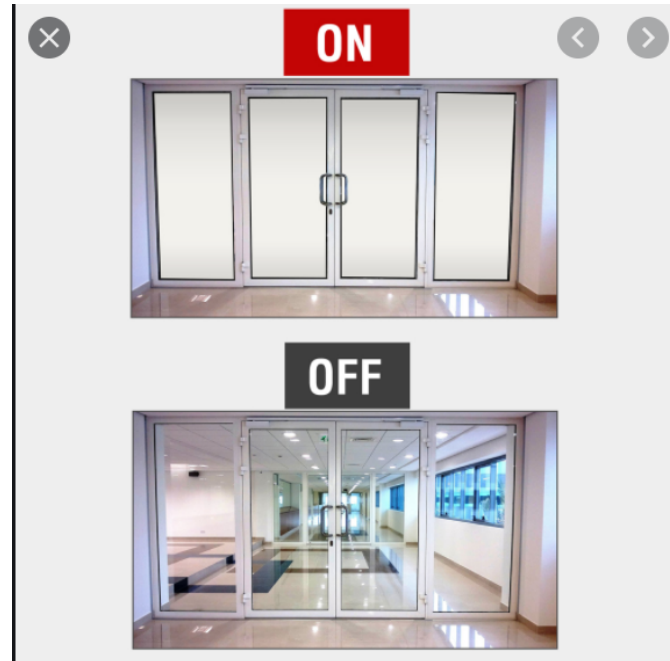

Figure 14 - Example of how a PDLC film would look when placed inside or on a door (Image taken from [techinstro.com](http://techinstro.com))

### *One-way Mirror*

If we do not elect to use the rotating polarizers method for tinting, we could still achieve privacy by using a one-way mirror. This one-way mirror would be placed on the outside of the window, allowing for only the inside viewer to see through the window. This method is good because it allows for privacy without trading off the ability to see through the window, but it is not switchable which is not ideal for the customizability of the window. The window may also work to allow for people outside of the window to see in when it is dark outside due to inside lights causing the one way mirror to turn into a reversed one way mirror.

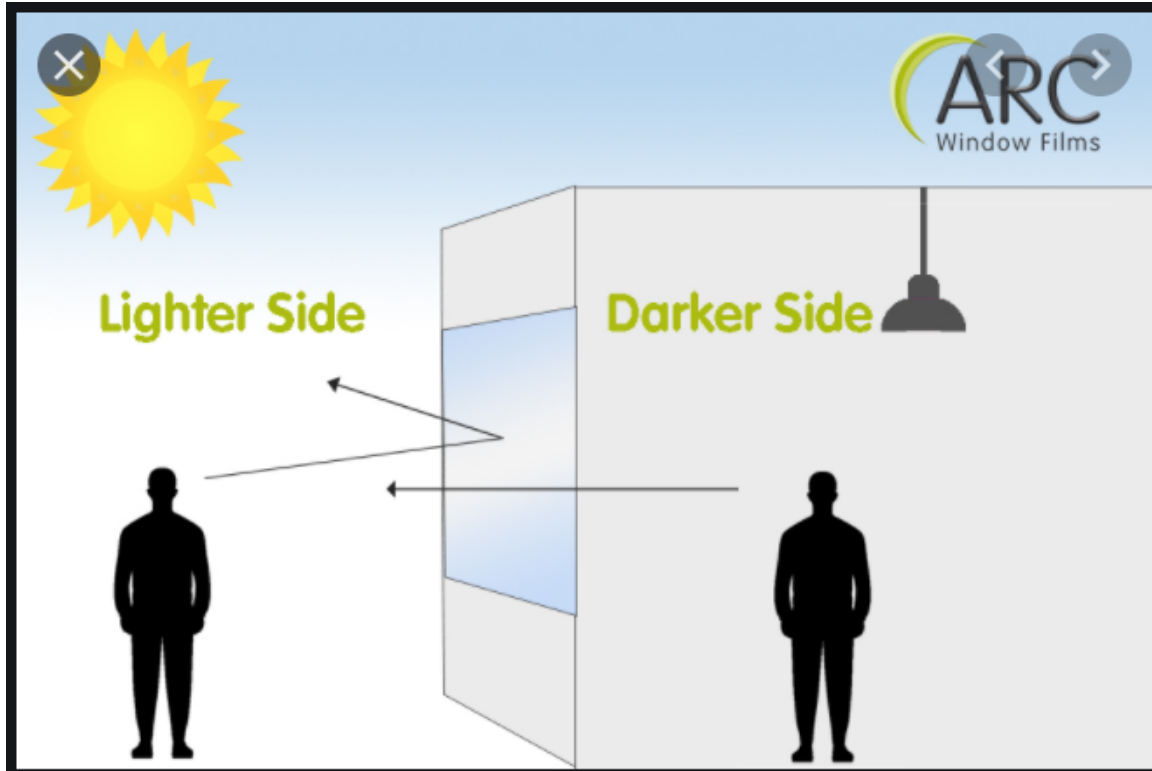

Figure 15 - Image depicting how a one way mirror functions. (Image taken from [arcwindowfilms.com](http://arcwindowfilms.com))

## Colorful Lighting Mechanism

### *Color Changing LEDs*

Upon further research, we found that it would be very difficult to find a transparent film or material that could be placed onto the window to diffuse/spread the LED light across the window. Our original plan was to have source lights mounted around the window and faced towards the center of the window, so that the colorful light would propagate across the entire surface. Since that initial idea was not feasible, we will attempt to use high-power color changing LEDs placed outside the inner pane and faced to shine towards the inside of the window.

The goal is to have the colorful light be shone into the room, but be bright enough so that the color of the light is still visible even with the privacy screen turned on. We hope that the privacy screen could then glow whatever color the LED is set to. We know that the privacy screen will allow some outside light in. But we must test it out to see how much optical power must be incident onto the privacy screen in order for the light to shine through the privacy screen in privacy mode.

Based on the results of that experiment, we will determine if we can obtain LEDs powerful enough to achieve this goal.

We do not want to sacrifice the colorfulness of this feature, as the whole point of including LEDs is to provide a unique lighting effect that is bright, visually appealing, and variable in color. In order to achieve the color customizability that we want to offer, the best option is certainly LEDs. LEDs are inexpensive as compared to other lighting methods, they allow for a very wide range of color combinations, and they can be made to be very small and powerful.



Figure 16 - Color changing LED bulbs (<http://www.c2clights.com/RGB38.html>)

## Sensors and Detectors

### *Video Camera Motion Sensor*

The video camera motion sensor also known as VMD functions by tracking the pixels shown on screen. When the pixels change from any movement the software activates and begins to record. As such the software allows for users to select areas of the picture to be monitored. This means only the pixels in the area selected will activate the motion sensing technology. Due to the nature of pixel activated VMDs the changing of light in an area can cause false activations. To combat this the user can select a specific percent of pixels needed to change in order for the recording software to activate.



Below is a picture of a small camera that uses VMD software. This camera can be mounted via glue or velcro to nearly any surface and has a 145 degrees worth of viewing angle. Our goal for these motion sensors would be to set the camera facing the inside of the window and select a horizontal rectangular area of interest running across the middle of the picture to detect when the user has walked into the frame. We would also be mounting one inside the window frame facing out and repeat the horizontal activation area to detect when a person has entered into the frame.

The users would have the ability to select privacy modes when either a person outside the window walks by or when they are walking inside the house which would activate the privacy screen.



Figure 17 - 40 mm width by 40 mm height by 25 mm depth miniature camera.  
(Image obtained from amazon.com)

The picture above is an example of a video camera that uses pixel change activation technology in order to record or detect motion. The camera would be connected to our PCB and alert the user to movement anytime someone or something has crossed into the marked activation area that we could customize based on the location of the window.

### *Ultrasonic Motion Sensor*

The ultrasonic motion sensor uses ultrasonic transducers to produce a sound wave in the range of 30kHz to 10 MHz. These sound waves are above the range of human hearing. Typically an ultrasonic motion sensor setup consists of a transmitter that sends the sound wave throughout an area at a specific frequency and a receiver which will collect the sent signal. When no person is inside of the



area the sent signal will bounce off of the static objects creating reflections of the original signal.

The time taken for these signals to be received is proportional to the distance from the receiver to the transmitter. Once a person enters the area of waves the wave will reflect off of them and take less time to reach the receiver activating the motion detector.

The picture below shows how a signal is sent out (red wave) and reaches the object where the signal is reflected (blue wave) back to the receiver and the distance between the object labeled  $r$  is measured to determine the object location. This technology allows for ultrasonic motion sensors to precisely detect how many people are in the transmitted wave area at one time.

For our application we would use the ultrasonic motion sensor on the inside of the window unit, the transmitter would be mounted to the window frame and the receiver could be placed 30 feet in any direction inside the room. This would allow for in depth customization enabling the user to select when to activate the privacy film feature based on how many people reside in the room.

For energy saving purposes the user could also activate the window tinting features depending on how many people are inside the room to prevent the room from heating up during the middle of the day, allowing for maximum comfort for everyone inside the room.

This device could not be used to detect motion outside of the window as the receiver would need to be placed outside which hinders the motion sensing capabilities. Due to this we would be forced to use ultrasonic motion sensors in conjunction with another method to detect movement outside of the window.

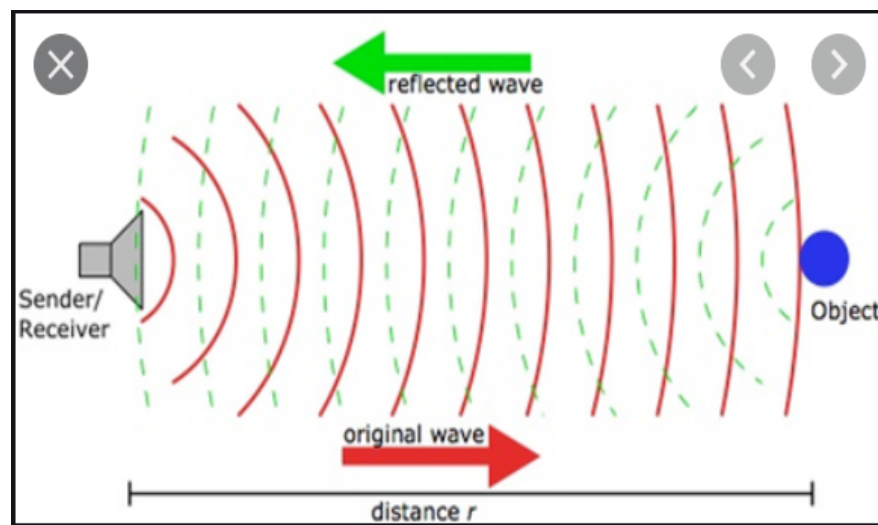

Figure 18 - Image depicting how tomographic motion sensors send sound waves out to detect movement. (Image taken from fierceelectronics.com)

The picture above represents an example of how a tomographic motion sensor functions in order to detect movement. The red wave moving from the sender in a direction left to right is a 30 kHz to 10 MHz ultrasonic sound wave moving through the air. When the sound wave comes into contact with the blue object on the far right of the image the sound signal is reverberated back, marked green on the image, towards the sender where a receiving module is there to capture it.

The distance label  $r$  is then calculated using simple trigonometric functions in order to determine how much far away the object is. As signals continue to bounce off the object the distance from the receiver constantly changes, this change in distance alerts the user to movement in an object. To incorporate this our setup would use the ultrasonic motion sensor connected to the PCB and allow for alerts through the app to when someone is crossing in range of the motion sensor.

### *Tomographic Motion Sensor*

Another applicable technology that can be used for motion sensing is tomographic motion sensors. Tomographic sensors work by using a system of nodes placed around an area that communicate to one another. The sensors use 2.4 Ghz radio waves as their form of communication which is the reason for its ability to travel through obstacles.

The image below shows a tomographic motion sensor network, these nodes create a mesh network as shown below that can completely surround an area and go through almost any obstacle that obstructs its path that includes concrete, walls, and glass. However, it does not have the ability to cut through certain metals such as steel, iron or other such materials due to the radio band that is being used.

Due to the radio band method that tomographic sensors use, false detections are cut to a minimum as small insects or even small animals such as cats will not be detected. This technique is beneficial because it can be completely hidden from view i.e. inside our window frame and behind walls allowing for us to achieve the aesthetic look that we are striving for. It also allows for virtually no maintenance as dust and dirt does not affect the systems efficiency. This method could be employed inside the window unit we build and the nodes could work in conjunction with other nodes placed throughout the house.

When the node near the window detects human presence our app could turn on the privacy film to allow for automated privacy. This system would not work to detect motion outside of the house as it would require nodes to be placed outside of the window unit where it would be exposed to the elements.

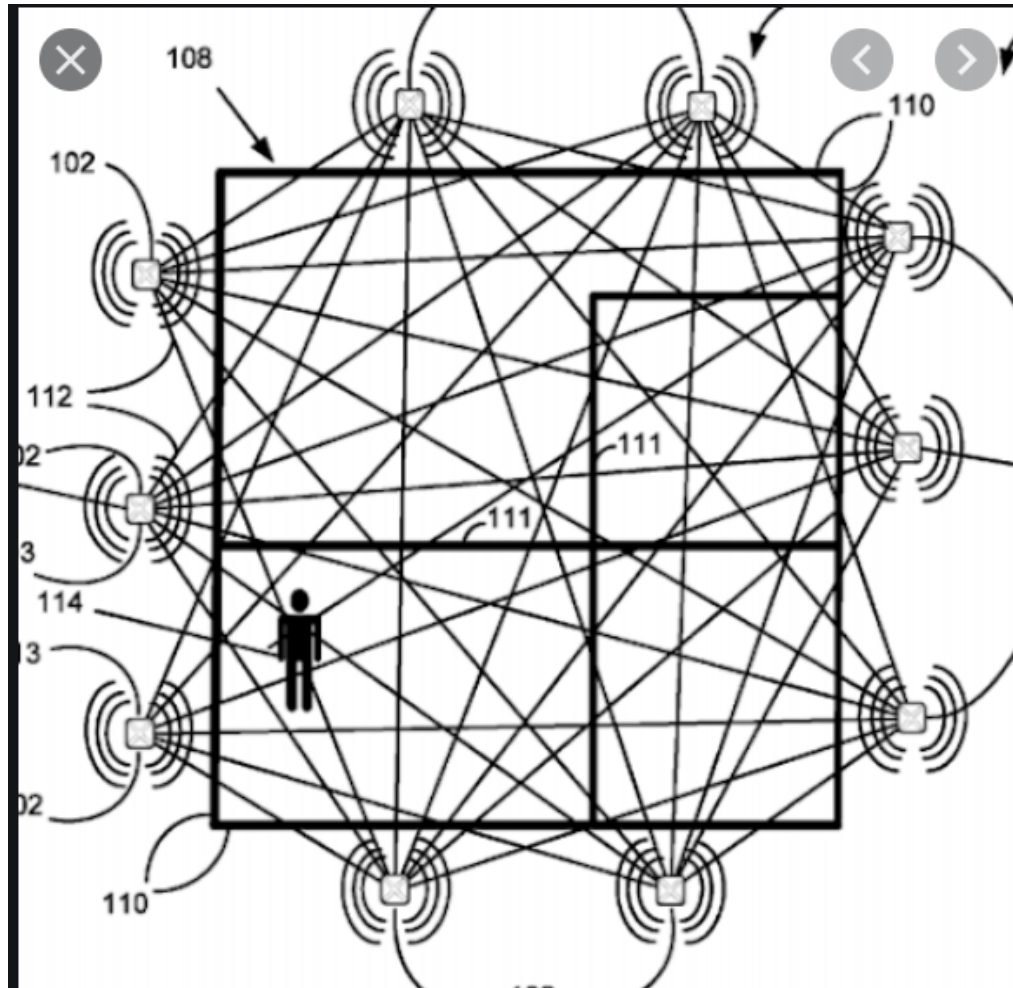

Figure 19 - Mesh grid of Tomographic motion sensor that sends radio waves out and detects disturbances in the waves to find movement. (Image taken from [dangerousprototypes.com](http://dangerousprototypes.com))

The picture above represents many nodes of a tomographic motion sensor. The nodes must be placed in multiple areas where they will send out radio waves in the 2.4 GHz range. The thin black lines represent the radio waves being sent from the grey square transmitters where they move throughout a room. The thick black lines represent walls. As shown above the radio waves are able to pass through most walls with minimal effects on the signal and can be used to detect movement even through walls.

The person in the image represents someone entering the area of the transmitters. When the radio waves come into contact with an object as large as a human the closest node or receiver will interpret the sent signal and recognize that a large object has been placed inside the room. If that object in this case a person continues to move the mesh nodes will then alert to the presence of a moving object inside the room. These nodes would have to be placed inside the

window unit and around the inside of a house or outside exposed in the elements in order to function as a motion sensor network. They would all be connected to the PCB and communicate with the phone app in order to alert the user of any movement inside it's range.

### *Microwave Motion Detector*

Microwave motion detectors also known as doppler radars work by sending continuous microwaves in the range of .3 GHz to 300 GHz from the sensor. When the wave comes into contact with an object a phase shift occurs in the frequency of the wave. When the reflected wave of different phases is read by the receiver it alerts the user to the presence of someone in range of the sensor.

The image below shows how this works, the green wave is the wave being sent and when it comes into contact with the hand the red wave that is reflected becomes amplified and shifts phase allowing for the receiver to detect the phase shift. Microwave motion detectors are unaffected by temperature and consume very little power making them ideal for our window which will have other electronics inside drawing power.

These motion sensors also have the advantage of being able to penetrate through walls and have high bandwidth and transmission rate. The microwave motion sensor could be placed inside the window unit facing outside and inside where it could detect both the motion of the user inside and people walking by outside in order to activate the privacy screen.

The non-temperate advantage of these makes them ideal for extremely cold or hot environments where temperature based motion sensors may struggle. Microwave motion sensors are so precise that any slight vibration or movement in the environment can falsely alert the user of motion; this disadvantage would prevent it from being able to face outwards as it would be tripped often by wind or other insects or animals passing by.

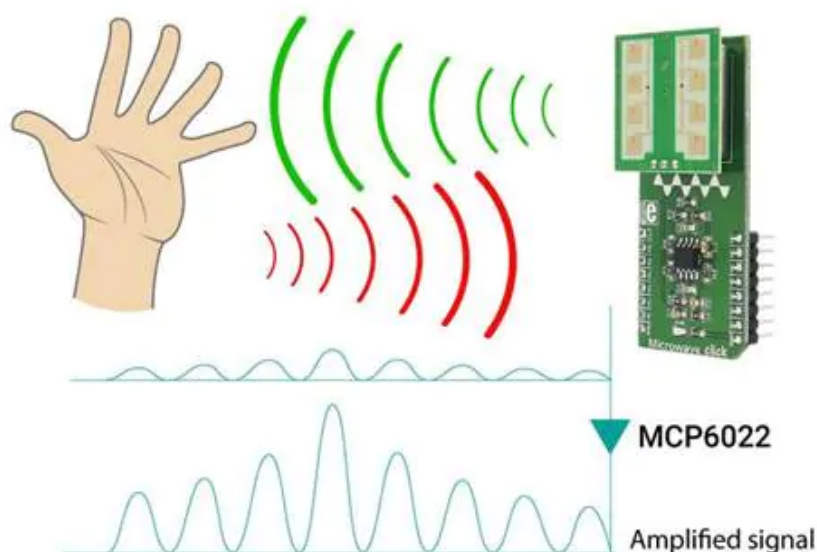

Figure 20 - Frequency of wave reaching the object causes a phase shift in signal and is amplified sending it back to the detector to sense motion. (Image taken from arrow.com)

The image above shows an example of how a microwave motion sensor or doppler motion sensor functions. The green wave is the transmitted wave being sent from the sensor. When the green wave meets an object in this case a human, the reflected wave undergoes a phase shift and the signal is amplified. When the red wave meets back at the sensor the sensor is able to calculate the phase shift and determine how far away the object is. As the object moves through space, the sensor is able to see the different phase shifts and alert the user to movement when the movement is in range. This sensor would be connected to the PCB and function with the phone app in order to alert the user to movement outside or inside of the window.

### *Passive Infrared Motion Sensor*

Passive infrared motion sensors also known as PIRs work by detecting changes in infrared radiation in an area. According to Wien's law all objects that have a temperature above absolute zero will emit radiation. Therefore Humans and animals alike produce radiation, passive infrared systems would detect the presence of them along with any other warm bodied object. The PIR system we would be interested in uses a positive and negative detector. When a warm bodied object passes in front of the first detector a positive pulse is generated, as the object moves the second detector generates a negative pulse.

Using two operational amplifiers, the positive and negative pulses are turned into a signal that alerts to the presence of a moving object. The picture below represents a visual guide on how a PIR system works, the human highlighted in red is the warm body as he moves across the detection plane the positive and negative pulses are sent to the operational amplifiers and the signal is generated to alert the user of movement. Due to the sensitivity of PIRs towards warm objects they can be equipped with an optical filter which limits the wavelength of light to a narrow range so as to only detect humans. Using black body radiation and Wien's law humans produce radiation around 9.5  $\mu\text{m}$  in wavelength.

The optimum optical filter to be fitted on the PIR system would detect wavelength from 7  $\mu\text{m}$  - 14  $\mu\text{m}$ . The amount of area that can be covered by the PIR is determined by the type of lens placed in front of the PIR. Without a lens the PIR can only detect distances up to roughly 1 meter. For our case we will be looking at using a fresnel lens which would extend the range of the PIR up to 30m.

If the passive infrared system is chosen we would use two PIR systems, both mounted inside the frame of the window, one facing outwards and one facing inwards. This setup would allow for privacy screen connectivity to ensure the user has automated custom controls when someone is passing outside the window or when the user is walking past the inside of the window.

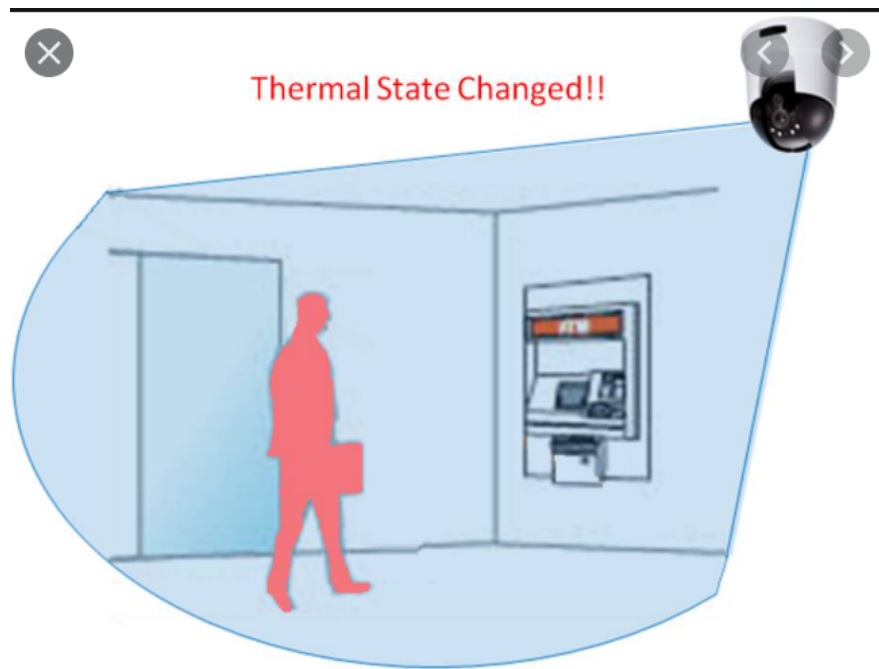

Figure 21 - PIR detection showing how the thermal state of detection area is changed when a living object enters into range. (Image taken from [instructables.com](http://instructables.com))

The image above shows a thermal imager in the top right and a human standing inside the range of the imaging system. The thermal image range marked in blue uses Wein's law that all living objects produce heat in order to sense the detection of certain wavelengths of light given off by humans to alert the user to someone coming into range of the sensor.

As shown above whether the object is moving or not if the infrared sensor detects a body of heat inside the filtered range then the sensor is tripped. This would connect directly into an arduino which would communicate with the PCB. When the signal is sent for detection of a human, the phone app would alert the user to the presence of someone or something inside the range of the sensor.

### *Light Dependant Resistor*

Light dependant resistors also known as LDR are placed into an electronic circuit in order to detect when light is incident on the resistor. The LDR works by changing the resistance of the diode when light becomes incident on it. In near complete darkness a LDR can up a few megaohms of resistance which prevents voltage from passing through it and continuing on in the circuit. However when light becomes incident on the resistor the LDR's resistance drops down to only a few hundred ohms allowing for the voltage to cross.

The LDR is made of semiconductor material that has very few free electrons. When light becomes incident on the resistor photons are absorbed giving the electrons enough energy to move, lowering the resistance. The picture below represents a simple diagram on how an LDR functions, the LDR on the left has no light drastically increasing the resistance, when the light is turned on the resistance decreases and voltage freely crosses the circuit.

The resistor can react to different frequencies of light being incident on the resistor to optimize the LDR effect. This can be customized to fit our application which would be using sunlight. LDR's have many advantages one such advantage is the cost to manufacture them is very low, this would allow for us to purchase an LDR and incorporate it into our window with minimal strain on our budget.

They are also a form of passive light detection meaning we would not be able to extrapolate precise values of how much light intensity is incident on the LDR. If the LDR is used it would be placed on the outside of the window frame which would allow for sunlight to become incident upon its surface. When the sunlight reaches the LDR if the user has selected an automated energy saving mode the window tint will darken up to its max tinting strength in order to block the most amount of light.

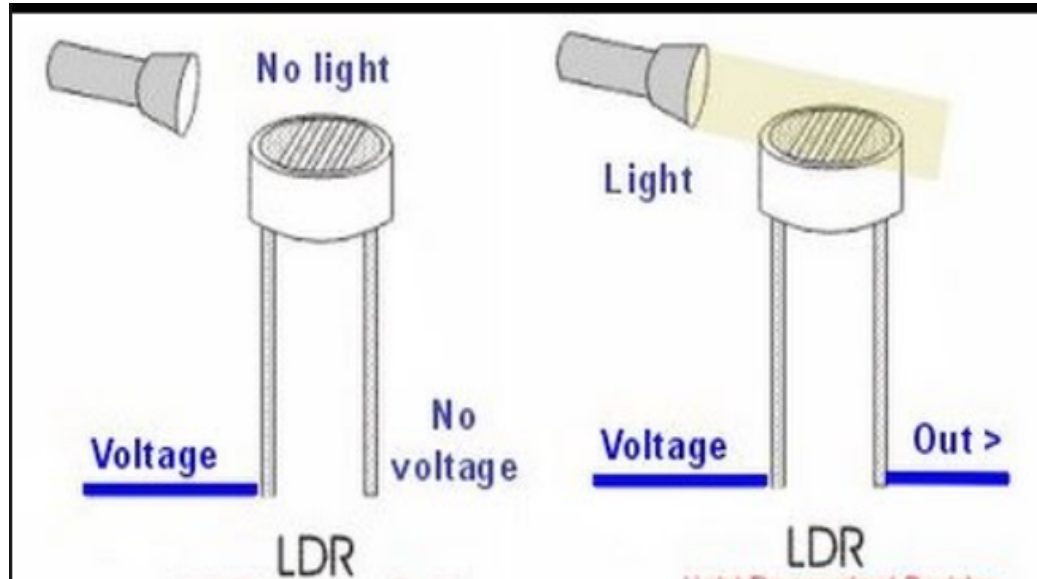

Figure 22 - LDR example showing how when light is incident on diode voltage is produced. (Image taken from Nguyen Thanh Tung, Arduino tutorials.)

The picture above represents how a light dependant resistor can be used to detect incoming light. The picture on the left represents a resistor when no light is incident on it. At this point the resistor has extremely high resistance which prevents voltage from passing it. The picture on the right shows when light becomes incident on the resistor the resistance drops drastically allowing for voltage to cross.

As the light intensity increases the lower the resistance on the light dependant resistor becomes allowing for higher voltage across it. This setup could be connected to the front of the window unit in order to determine when light was incident on it. The light dependant resistor would be connected with an arduino and communicate with the PCB to relay that information to the polarizers in order to determine how much light should be filtered and how much light should be allowed to pass.

## Luminance and Illuminance Photometer

A luminance photometer is used to determine how much light is illuminating on a surface. The photometer measures this light in lumens or cd per meter squared. Due to the photometer receiving the measurement from the surface of an object the acceptance angle of light from the object must be well defined along with the total surface area being measured and the shape of the surface. An illuminance photometer on the other hand is a direct measurement of energy that is incident upon the surface of an object.



The illuminance meter takes light directly from the light source in order to determine how much energy is incident upon the surface. The illuminance meter measures light in lux per foot times candela. The meter itself uses a detector head that is cone-like in shape as shown in the picture below.

This cone-like shape causes off axis light measurements to become in-accurate. This can be corrected with a cosine diffuser placed over the sensor filter and head which achieves more accurate readings. The picture below demonstrates the difference between an illuminance meter and a luminance meter, as shown the light source is measured directly with the illuminance detector and the reflected light is measured with the luminance detector. The picture also illustrates the difference between the two units of measurements of the illuminance meter compared with the luminance meter.

The illuminance meter can use filters on the head of the detector in order to cut out unwanted wavelengths of light. Using filters on our detectors we could use two illuminance meters; one in the visible light spectrum, and one in the infrared, to allow for greater customizability to the user. Both illuminance and luminance meters typically use photodiodes in order to measure the intensity of light.

A photodiode works by using the photons from the incident light to excite electrons which in turn generates an electrical current that can be read with a circuit board. Most photodiodes operate under reverse bias conditions and are relatively cheap to produce and purchase. Both applications could be used to determine precise measurements of how much light is being incident on the window. With this data we could select certain light intensities to activate specific levels of tint to have more customized energy saving modes.

The illuminance meter would be mounted in front of the second window pane, behind the first two or three polarizers where it could read precise measurements of sunlight entering through the window and the polarizers. The luminance photometer would have to be mounted outside of the window frame itself in order to have an acceptance angle that would accurately read the light coming through the polarizers. Therefore it would most likely be mounted to the inside frame of the window facing the polarizers which would produce a negative aesthetic appeal to our product.

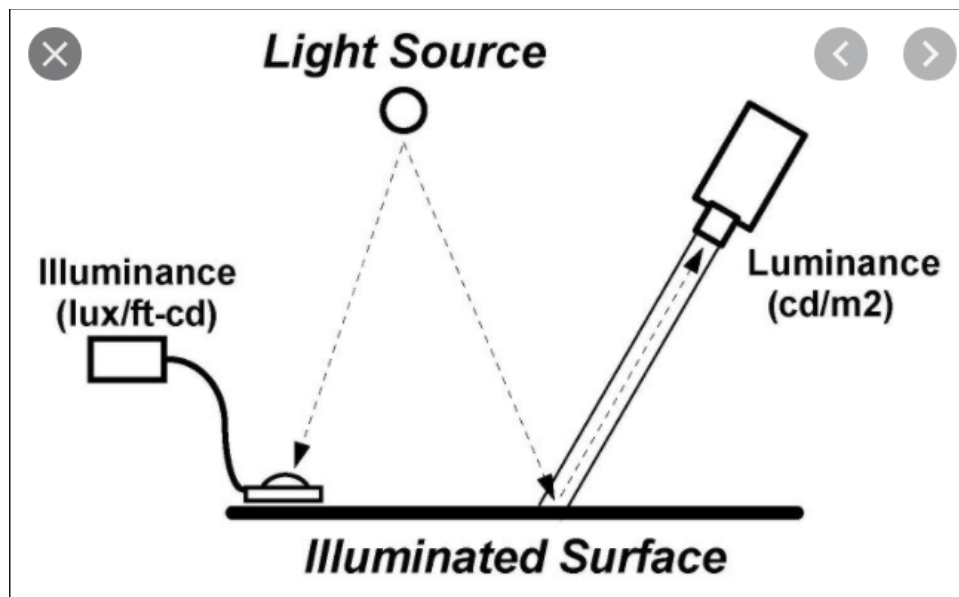

Figure 23 - Example of the difference between luminance and illuminance.  
(Image taken from [visualexperts.com](http://visualexperts.com))

The other alternative to light dependant resistors are illuminance and luminance meters. The difference between illuminance meters and luminance meters are shown above. The illuminance meter directly reads the light that is incident upon a surface. In our case it would be used to detect how much light is incident on our window.

The luminance meter works by measuring the reflected light that is coming through or off of a material. The illuminance meter would be placed on the first polarizer in order to recognize how much light intensity is being placed onto the window. From there the illuminance meter would communicate with an arduino to make calculations on how much light intensity is actually on the window. It would then communicate with the PCB in order to tell the polarizers to rotate to allow more light or block light from entering the window.

The luminance meter would be placed inside the window unit at the very front facing the first polarizer. When light strikes the window the luminance meter would read the reflected light coming off the window and determine the intensity in the same manner as the illuminance meter. It would then send that information to the PCB where it could be communicated to the polarizers in order to rotate them to the desired output intensity.

### 3.3. Strategic Part Selection

After deeply examining and critiquing each of the aforementioned technologies and alternatives, we put together component comparisons for each corresponding element of the project. These comparisons are discussed textually and are also displayed in tables to make it easy to see the most important and relevant aspects of each option. For each component that we select, we mention why we chose that part, and in some cases we identify the next best option.

#### Tinting Mechanism

To provide our window with a variable tint option, we will incorporate some iteration of the rotating polarizers technique. Despite the extra work that it will require to make the window circular and to include a rotating mechanism, the ability to precisely vary the tint level provides a feature that is extremely difficult to find.

We hope to maximize the upper limit of our window's transparency, but if the polarizers prevent the window from achieving more than 50% transmission, that downside will not be significant enough for us to consider using a different tinting option. The photochromic film cannot be controlled in the way that the polarizers can, and the motorized blinds are not an option for this project if our goal is to contain all of the window's components within a single window unit.

The only website that I found which offers a variety of large area polarizing films is called polarization.com. Since our window may be as large as 1 ft. in diameter, we may need at least 2 sq. ft. of polarizer in order to cover both panes of the window. The website that I mentioned has lots of options available. Some of their attractive products include transreflective polarizers, fully laminated polarizers, and high temperature polarizers. All of those options allow for 38% - 43% transmittance of randomly polarized light. The high temperature polarizer is especially attractive, considering they have been tested to withstand temperatures of up to 221°F. Since our application is a window, heat resistance is very important for our design.

Polarization.com has also stated that their films are cuttable, so making them circular should not be an issue. In my past experience using linear sheet polarizers, I noted that some polarizers of low quality are susceptible to having reduced polarization effects around the edges of the polarizer. Based on my research, this could be due to the way in which the polarizers are cut. Nonetheless, to stay on the safe side we intend to apply more than 1 ft. diameter of film onto each pane.

We will cut an excess amount and wrap it around the edges in order to ensure that the entire visible portion of the window tints properly without issues. This is especially important for when we want to black out the windows. If the edges are not polarized properly, then the center of the window will be able to achieve 0% transmittance while the edges will still allow some light through. I have already reached out to the company. Once the design for the window is complete, I will purchase the polarizers.

After reaching out to the sales representatives of Polarization.com, I am leaning towards purchasing their standard linear polarizer film. It is the most cost efficient, and I have been informed that they can withstand temperatures of up to 60°C (140°F) in humid conditions. I have also been reassured that cutting the film with scissors will not cause any undesired edge effect.

The laminated polarizers are also attractive, but we will evaluate the pros and cons between the film polarizer and laminated polarizer after confirming the design of the window. If we purchase films to attach to each pane of the window, then we must ensure that the window panes themselves can rotate. It may be easier, however, to purchase the laminated polarizers and simply rotate them as opposed to rotating the entire window pane. Table 3 shows a comparison between the options that Polarization.com offers.

Type of Polarizer	Pros	Cons	Cost
Polyvinyl Linear Polarizer Film	Inexpensive, thin, custom sizing	Non-adhesive	7 cents/square inch
<b>Fully Laminated Polarizer</b>	<b>Rigid, easy to rotate, custom sizing</b>	<b>Expensive, non-adhesive</b>	<b>17 cents/square inch</b>
High Temperature Polarizer	High operating temperature, humidity resistant, blocks UV, adhesive	Expensive, size not fully customizable at time of purchase	43 cents/square inch
Trans-Reflective Polarizer	Reflective side provides privacy, adhesive	Expensive, size not fully customizable at time of purchase	42 cents/square inch

Table 3 - Comparison between polarizer options offered by Polarizaion.com

## Summary

The fully laminated polarizers have been selected due to their relatively inexpensive cost, rigidity, the ability to cut the film ourselves, and decent operating temperature (176°F in dry conditions, 140°F in humid conditions). The lack of adhesive will prove to be a minor setback, as the rigidity was necessary for ease of rotation. The original plan was to attach a laminated polarizer to the rotating bearing and to adhere a thin film polarizer to one of the glass panes; the rigid film would prove to be less problematic to rotate than a flimsy polarizing film. Unfortunately, the sales representatives that I spoke to informed me that it is not easy to adhere their thin film polarizers to glass. So, we decided to purchase two laminated polarizers, one of which will be rotated and the other attached to a glass pane and kept in a stationary position.

## Privacy Screen

We will use a PDLC film to act as a switchable privacy screen. The ability to switch between privacy mode and transparent mode in a matter of seconds is extremely attractive. The appearance of the window when in privacy mode will also be very aesthetically pleasing. The reflective polarizer cannot be turned off, which is counterproductive to our goal of making this window as interactive as possible. The same applies to the one-way mirror.

There are quite a few suppliers of PDLC screens who manufacture and sell their products online. The largest manufacturers, however, appear to be ElectraTint, Smart Tint, Invisishade, and Rayno Film. I have reached out to all four, requesting pricing information as well as technical specifications. A comparison is done in Table 4 below.

Manufacturer	Support Circular Shape?	Dimmable via Applied Voltage?	Pricing Quote
Smart Tint	Yes (shipped circular)	Yes	~\$252.90
ElectraTint	Did not respond	Did not respond	Did not respond
Invisishade	No (cuttable using sharp scissors)	Yes	\$199
Rayno Film	Did not respond	Did not respond	Did not respond

Table 4 - Comparison between PDLC film providers

## Summary

The obvious choice seems to be Invisishade. Their price is much much better than the price of Smart Tint, and their films are dimmable and cuttable. The other two manufacturers did not respond to me despite reaching out to them multiple times. Since we cannot wait for their responses, I have ordered a 16" x 16" film from Invisishade.

## Color-Changing LEDs

Color-changing LEDs are abundant and easy to find when shopping online. There are many different types to choose from, such as standard household light bulbs, LED strips, spotlights, and other unique styles. Since our window is not expected to be very large, the best solution may be to purchase color-changing LED strips to place around the outside edges of the window and directed towards the inside.

We still need to get a hold of the privacy screen first to determine the minimum incident power and incident angle that will allow for light to illuminate the entire PDLC film, but my assumption is that LED strips will be ideal. The unassuming and unobtrusive size of the LED strips is perhaps its most attractive characteristic. The mounting angle and optical power will determine whether or not they can be used in conjunction with the PDLC film.

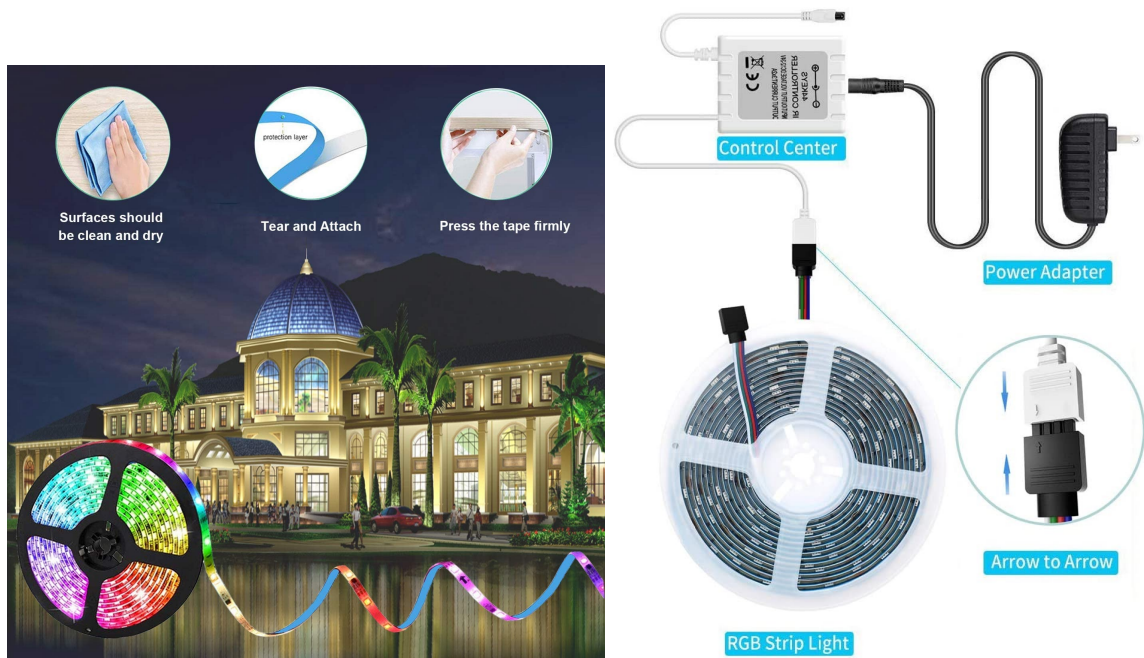

Figure 24 - Color changing LED strips (Photo taken from Amazon.com)

## *Summary*

We have purchased a set of color-changing LED strips, but we are waiting for the privacy screen and polarizers to arrive so that we can test them with the LEDs. If they do not work well together, we may need to consider another lighting alternative.

## **Motion Sensor**

The motion sensor will be used to detect movement both inside the window and outside the window. The sensor must have the ability to detect movement up to 10 meters away to allow for the automated privacy feature to activate when someone is walking by the outside of the window. In order to select the best type of motion sensor for our needs we have constructed a table to break down the most important aspects we need in our motion sensor.

<b>Motion Sensor Type</b>	<b>Detection Distance Possible</b>	<b>Minimum number of devices needed to function</b>	<b>Power Draw per Day</b>	<b>Cost</b>
Microwave Motion Detector	8 - 25 meters	1	1.5 W	\$50 +
Tomographic Motion Sensor	9 meters	2	5 W	\$64+
Ultrasonic Motion Sensor	20 meters	2	23 W	\$200+
Video Camera Motion Sensor	11 meters	1	6 W	\$30+
<b>PIR Motion Sensor</b>	10 meters	1	0.8 W	\$10+

Table 5 - Comparison between motion sensor technologies

### *Summary*

After comparing the different types of motion sensors, the microwave motion sensor and the passive infrared sensor are the two best choices. One area the passive infrared sensor beats the microwave sensor on is the false detection rate.



Due to microwave sensors being very sensitive to micro vibrations in the detection area it can cause the detector to falsely detect motion. Because our motion sensor will be facing outside, wind, trees, insects and other moving objects could trip the microwave motion detector.

The PIR motion sensor on the other hand has the ability to limit the detection wavelength to specifically target when humans are in range via a filter. Therefore the passive infrared motion sensor overcomes all of our challenges and requirements in order to successfully create a motion sensing device in our window unit.

When choosing which PIR device to use we must consider the maximum range it will provide, along with the acceptance angle and how much power it will consume in order to operate. Below are a list of possible contenders for our motion sensor.

## PIR Motion Sensor

Motion Sensor SKU	Detection Range	Acceptance Angle (degrees)	Size	Input voltage (DC)	Operating Temp (Celsius)
113990020 seedstudio	3 - 7 meters	120	24mm* 32mm* 25mm	4.5V-20V	-15 to +70
101020060 seedstudio	3 - 10 meters	120	45mm* 35mm* 19.5mm	3V-5.5V	-15 to +70
LPIR-6A superbright leds	0 - 4.5 meters	120	20mm* 30mm* 30mm	12V-24V	-20 to +60
Panasonic AMN34111 alliedelec	3 - 10 meters	110	5mm* 8mm* 10mm	5V	-20 to +60

Table 6 - Comparison between PIR detectors

## *Summary*

The table above provides a breakdown of each of the different motion sensors that are available to us that fit our needs. All three of the seed studio motion sensors and the LPIR-6A provide the largest acceptance angle of 120 degrees. The Panasonic AMN34111 provides the lowest acceptance angle of 110 degrees or 65 degrees from the center of each side.

All four of the motion sensors are well within the required acceptance angle of 100 degrees total or 50 degrees from the center on either side. All of the devices provide a large range of required functioning temperature in freezing cold weather and very hot weather. With the seed studio 113990020 and 101020060 providing the best range of temperature from -15 celsius to 70 degrees celsius. The seed studio motion sensors come attached to its own style of arduino that monitors and reads the incident light for us. While convenient, these attachments hinder our ability to have a fully connected, modular system that allows for all devices to cross communicate.

The LPIR-6A allows for customized arduino boards to read information which is ideal for cross connections. However the input voltage of 12-24 volts is much higher than what we would like to implement. The extra voltage required could be incorporated however the distance of 0 meters to 4.5 meters of readable range is a much smaller range than our attempted minimum of 6 meters.

Finally the Panasonic AMN34111 does not come with an arduino board and is just the photodiode itself. This allows for the most customization of all the photosensors because we are able to build any board around it in order to fit size constraints of the window itself along with communication constraints of the PCB and the bluetooth transmitter. The AMN34111 also has the lowest required input voltage to function while exceeding our constraint of 6 meters of detectable range, detecting distances all the way up to 10 meters.

Using the Panasonic AMN34111 requires the sacrifice of acceptance angle for detection range but gives us superior customizability, equivalent or greater range to all of the other photodiodes, and greater communication across all of the other included devices in our smart window. Therefore we will be choosing the Panasonic AMN34111 as the photodiode of choice for our photometer.



Figure 25 - Panasonic AMN34111 Alliedelec

The image above is a picture of the passive infrared motion sensor that was chosen to be used inside of the window unit. The photo sensor uses a through hole mounting system and will attach direction into the PCB where it will send the information into an arduino board. Two of these will be mounted, one facing the inside of the window unit and one facing the outside. It operates at a supply current of 170 microamps and a maximum voltage of 6 volts which allows for the furthest detection distance of up to 10 meters.

## Light Detector

Our window will have the function to have energy saving modes which can be adjusted by the rotating polarizers. In order to change the polarizers based on the light being incident on the window we must choose between either the illuminance photometer, luminance photometer, or light dependant resistor. The light dependent resistor offers the cheapest solution out of the three. However it functions as a passive light detecting device, meaning that when sunlight becomes incident on the resistor it is either allowing voltage to cross and when there is no light it is not. This prevents us from being able to customize how much light we allow through our window based on how bright the sun is.

This leaves the option of the luminance photometer or the illuminance photometer. The luminance photometer has the ability to read the light being cast on the window in more precise measurements than the light dependant resistor however, due to it reading the reflections of the light on the window it must face the window but not be located on the window itself. This would cause the photometer to be sticking outside of the window unit detracting from the overall aesthetic appeal that we are striving for.

The illuminance photometer allows us to have precise measurements along with the ability to be placed directly onto the window unit itself. Therefore we will be building an illuminance photometer, making it as small as possible and placing it on the first polarizer ensuring that it is facing towards the outside part of the window.

The majority of heat caused from sunlight entering through the window is due to infrared light which accounts for 50% of the heat entering through a window. UV rays entering through the window account for another 26% of the heat produced. Therefore the photodiode's wavelength range will need to encompass both UV and infrared light. We will use a table to compare the possible parts that can be used for our purpose.

Photodiode	Detection Range (nm)	Active Area	Peak Wavelength	Responsivity (A/W)	Maximum Dark current (noise)	Cost
FDS010 Thorlabs	200 - 1100 nm	0.8 mm <sup>2</sup>	720 nm	0.44 A/W	1 nA	\$48.15
FD11A Thorlabs	320 - 1100 nm	1.21 mm <sup>2</sup>	960 nm	0.60 A/W	2 pA	\$14.58
<b>FDS1010</b> <b>Thorlabs</b>	350 - 1100 nm	100 mm <sup>2</sup>	970 nm	0.725 A/W	600 nA	\$55.73

Table 7 - Comparison between photodiode

## Summary

The table above provides important information in order to compare the different types of photodiodes that we have the ability to purchase to use in our photometer. As discussed previously around 50% of all heat generated through windows comes from infrared light with another 30% of the heat being produced

from UV light that is given off by the sun. Therefore all of the photodiodes must be able to detect light at those wavelengths in order for us to get the most accurate readings for an energy saving mode.

Photodiode FDS010 is able to detect half of UVC and all of UVA and UVB while covering most of the near infrared spectrum (700 nm - 1000 nm). Therefore it has the widest coverage range of all of the spectrums but in turn has the smallest active area in order to read incoming light. The peak wavelength for responsivity of this photodiode is at 720 nm and can produce a low 0.44 A/W at this wavelength. While this photodiode can read the most into the UV spectrum it lacks surface area for incoming light rendering it unable to accept light at larger acceptance angles efficiently and costing over \$48.

The next photodiode FD11A only provides detection in the UVB and UVA range going up to the near infra-red range. The active surface area is slightly larger than FDS010 but has a peak wavelength further in the near infra-red range at 960 nm with a responsivity of 0.60 A/W. The larger surface area and the high responsivity along with the extremely low price make this photodiode very appealing. However The small surface area may still cause acceptance angle issues and will require further testing in order to prove that it can read light at large enough angles to be accurate for window usage.

Finally the FDS1010 is almost identical to the FDS 010 however it reads a smaller amount of UV light but extends the surface area by almost a 100x. The increased surface area also provides much greater responsivity with 0.725 A/W at a peak wavelength of 970 nm. The FDS1010's large active area will provide the necessary acceptance angle required for the window to function properly, after testing the FDS010 if the photodiode does not provide the necessary results we will be using the FDS1010.

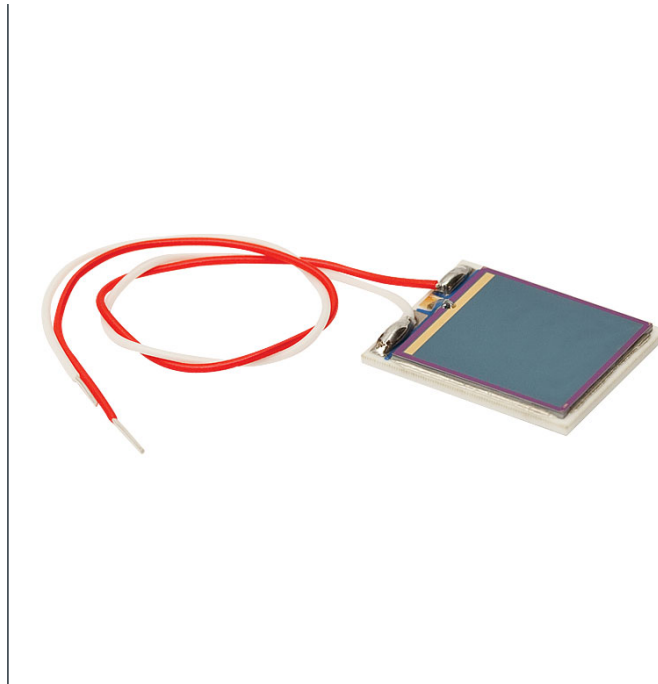

Figure 26 - Thorlabs FDS1010

The figure above represents the silicon photodiode, thorlabs FDS1010. As shown the device will be an unboxed wafer made of ceramic that contains one anode wire (white) and one cathode wire (red). The anode wire will be the wire that produces the current from the incoming light which can then be converted to voltage and photocurrent.

## Power Supply

The role of the power supply will be to keep all of the electronics in the window powered, therefore to pick the power supply certain characteristics were analyzed for the smart window project including: voltage required by each of the components, current required by each of the components, and maximum power dissipation across the components. These three characteristics are the most important for powering the window

The voltage is important because we require enough voltage to turn on each component in the circuit. Not supplying enough can lead to loss of functionality for the smart window and supplying too much voltage can damage the components. For the current, all of the electronics will only take as much current as they need, so supplying more current than necessary will not be a problem for most instances. However, each component in the window has a maximum power rating so the power consumption of each component must not exceed its rated

value or else failure of the component will occur and the components will heat up and possibly catch fire.

The first AC to DC power adapter considered for this project was the TMEZON AC to DC power supply. This power supply could utilize an AC wall input voltage in the range of 100V to 240V allowing frequencies in the range of 50Hz - 60Hz and it could supply an output DC voltage of 12V with a current rating of 2A with a max power dissipation of 24W. In terms of the connector it had a 2.1mm by 5.5mm plug with a center positive configuration. This power supply also has a cord length of 8 feet allowing for maneuverability in terms of connection to both the wall and the smart window because a shorter cord would limit the placement of the window and would make it harder to install.

This power supply is also a regulated switching power supply which gives it the characteristic of being more efficient than linear power supplies and of being able to handle higher power applications. This type of power supply also is more common and has a smaller form factor than linear power supplies making it an even more attractive choice. This adapter on the market is currently priced at \$7.99 making it a cheaper choice than some of the other adapters on the market which require a purchase of not just the adapter but of additional cables to use it.

This next power adapter utilizes an AC wall input voltage in the range of 100V to 240V and it also can take frequencies of 60Hz and 50Hz. It can supply an output voltage of 15V with a rated current of 2A with a max power dissipation of 30W. This adapter also has a connector plug with dimensions of 2.1mm by 5.5mm and it also comes with an extra attachable connector for devices that can only use a 2.5mm by 5.5mm plug.

For this adapter the power cord is only 6ft long which is shorter than the TMEZON adapter mentioned previously which is a negative for this adapter because now the placement of the smart window becomes more limited. Currently the market price for this adapter is \$11.99 which is more expensive than the TMEZON adapter considered previously which is a negative for this adapter but the tradeoff is more voltage for the smart window as well as more connection possibilities because it comes with the other connector.

Below is a table that compares the power adapters that were analyzed. The chosen power adapter will be highlighted.

	TMEZON Power Adapter	Maxson Power Adapter
AC Input Voltage	100-240V	100-240V
DC Output Voltage	12V	15V
Current Rating	2A	2A
Frequency Range	60Hz	50/60Hz
Max Wattage	24W	30W
Power Plug Dimensions	2.1mm x 5.5mm plug	2.1mm x 5.5mm and 2.5mm x 5.5mm plugs
Cord Length	8ft	6ft
Price	\$7.99	\$11.99

Table 8 - Power Adapter Comparisons

### *Summary*

The adapter that was ultimately chosen was the TMEZON adapter which gives us a longer cord with a reasonable voltage supply at a lower cost and with a smaller power consumption. The TMEZON adapter also has a larger efficiency due to it being a switched power supply versus the Maxson adapter where the type of power supply was not mentioned. For this project we also do not require an extra connector so purchasing the Maxson would use up money that does not need to be spent. A higher voltage would be more beneficial but if the voltage is not enough it can always be stepped up or down using a boost converter or a buck converter which would be a cheaper alternative.

In addition to the AC to DC adapter it was also required to purchase a power jack in order to supply the electricity to the PCB board. This power jack had to have the same dimensions as the plug of the AC to DC adapter and it had to have a rated voltage that was above that which the power supply could provide so that the component would not be damaged. It also had to have an available footprint in order to design the PCB schematic. It also had to be purchasable at a reasonable price. The type of connector also had to be female in order for the male plug connector to match with it. The polarity of the connector must also match that of the power adapter cable.

The connector that was ultimately decided on was the CON-SOCJ-2155 manufactured by Gravitech. This connector was chosen because it has an inner diameter dimension of 2.1mm and an outer dimension diameter of 5.5mm which



is an exact match for the power supply that was chosen so it is known that they will fit into one another. This connector's type is also female which is what is desired to connect the male power adapter cable. The polarity of the connector also matches that of the power supply adapter because the sleeve of the connector which is the outside part of the connector has a negative polarity and the tip of the connector which is the inner part of the connector has a positive polarity which is the same as the adapter which has a center positive configuration.

The voltage rating for this connector is 30V which is well above the DC voltage that will be sent through it by the adapter cable that supplies only 12V so it is known that the connector will not get damaged. The rated current for the connector is also 2.5A and we know that the power supply's rated current is only 2A so there will also not be any issues with this value as long as the current is maintained below 2A.

The price of this connector is \$1.00 for one connector which is a very decent price because we only need one of these connectors for the PCB board and if an extra one is needed for breadboard testing it is just \$1.00 more. This connector also already has a footprint and schematic design available to be used and its footprint is CON-SOCJ-2155 which will be used in the final PCB design.

## Motor Driver Selection

In picking the right motor driver to connect with the motors used for the rotation of the window film, certain properties were sought out. Namely we looked at the voltage needed by the motor drivers as well as the current to power the motors. The type of motor driver was also observed along with the compatible motors that can be used with it. The last properties looked at were the interface that the motor drivers could use as well as the price of the components to make sure we get the best performance motor driver at a reasonable cost, as well as how many motors we could power with one motor driver integrated circuit chip. Also motor driver modules were observed as well as a motor driver chip and they were compared to see which was a better option for the smart window.

The L923D motor driver module contains a L293D dual H-bridge driver chip which can be used to run four DC motors at the same time and change their directions independently. It can be used to control motors which operate from 3V - 16V and which operate with currents of 1A. The L293D IC module interfaces include microcontrollers such as Arduino, PIC, and ARM.

The IC inside of the motor driver module can also be used to drive stepper motors. The price of this module currently is at \$13.99. The disadvantage of this motor driver module is that it is larger than the L298N that is mentioned next; it is

also not sold in large quantities like the module mentioned next so if more of these modules are needed it would be a greater cost.

The L298N module uses the Double H Bridge L298N as the chip inside which can drive one 2-phase stepper motor, one 4-phase stepper motor, or two DC motors. It can supply a maximum of 46V to a motor and it can supply current up to 2A. The maximum power dissipation of this motor driver is 25W. It can also be interfaced with Arduino as well. It also contains other useful features such as a heatsink and a 78M05 voltage regulator. The price for a single module is currently at \$6.69.

This module also has the advantage that it is small and it does not weigh a lot. This module on the market can also be bought in bulk with some sellers providing as many as 5 of these modules for a low price allowing us to use as many modules as necessary if more are required or if the ones used in the smart window were to break or be damaged.

Instead of buying a module already created the L298 chip can be bought and the motor driver circuit can be designed on our own. This has some beneficial characteristics namely we can place the motor driver module on the PCB board rather than having to place it in addition to the PCB board. The window encasement will have limited space and therefore it would be better to integrate both the PCB and the motor driver module. The L298 motor driver chip can be created by many manufacturers and one of the ones that was observed was STMicroelectronics.

This chip can be purchased from Mouser Electronics. The motor driver chip found has the following characteristics: it has an operating supply voltage of 4.8V to 46V, an output current of 2A, it can control 2 motors the same as before and it has 4 outputs. The price for one chip is \$4.86 on Mouser Electronics which is cheaper than buying the module. However, other components would have to be bought to make the motor driver circuit work including diodes, resistors, capacitors and a possible heat sink in order to use the maximum current of 2A. This motor driver chip also comes as a through hole part.

The BTS7960 module uses the Infineon chip BTS7960 and it also has a double H-bridge driver circuit. It can supply a high current of 43A and it can be used with motors that need 5.5V - 27V. It can also be interfaced with Arduino for easy use. The current price on the market for this module is \$11.99 for just one module and this module can be used to control stepper motors. This motor driver module can be bought in pairs in case more than one are required for the smart window which is a plus.

Below is a table of the comparisons of the three motor driver modules that were analyzed as potential choices for the smart window project. The motor driver chosen is highlighted.

	L298N Module	L293 Module	BTS7960 Module
Motor Supply Voltage (Maximum)	46V	36V	27V
Motor Supply Current (Maximum)	2A	600mA	43A
Maximum Power Consumption	25W	Not given in datasheet	Not given in datasheet
Types of Compatible Motors	DC motors and Stepper Motors	DC motors and Stepper motors	DC motors
Max Number of Motors Controlled Per Module	4	2	1
Price	\$6.69	\$13.99	\$11.99

Table 9 - Motor Driver Module Comparisons

## Summary

The motor driver that was ultimately chosen was the L298N motor driver module purchased from Amazon.com. Not only did it have good voltage and current characteristics but also datasheets already exist with ways on how to wire the L298N motor driver module. Also there are more tutorials available on the internet as to how to use the L298N module versus other motor driver chips and modules which are not as common.

It is also cheaper to buy the motor driver module rather than have to buy the chip and assemble all of the components yourself. In addition to that the L298N module already comes with a heatsink so the max current of 2A can be used with the motors and it does not have to be purchased. The motor driver module can also be controlled via Arduino which is easily available and other motor driver chips and modules do not have as many tutorials on programming and use as this one. This module is also very small so fitting it into the window encasement should not be a problem.

## Motor Selection

After picking the motor driver the next parts that were selected were the motors that are going to be connected to the L298N in order to rotate the window film. One of the important characteristics that was looked at in picking the stepper motors was the step angle which indicates the amount of degrees that the shaft of the motor advances per step. This quantity is given in degrees per step or can be given in steps per revolution. The voltage rating is also another important specification and it indicates the maximum voltage that the coils of the motor can tolerate. The current rating also indicates the amount of current that is needed in order to get the motor running.

The inductance of the windings is also an important characteristic because a higher inductance means that the motor will not be able to spin as fast. The holding torque is another important specification because it measures how strong the motor is when it is energized. The detent torque is another torque that is measured and it details the amount of force created by the stepper motor when the coils are not energized and it is also called the residual torque of the motor.

The polarity of the stepper is also analyzed because stepper motors can also come in either the bipolar and unipolar stepper varieties and bipolar steppers produce a higher torque than the unipolar steppers. However unipolar stepper motors have a higher max speed than bipolar steppers and bipolar steppers are harder to control than unipolar steppers. The price of each stepper motor was also analyzed in order to make the best motor for the most affordable price. Common stepper motors on the market were analyzed and the following table compares some of them on the characteristics mentioned prior.

Stepper Motor Observed Characteristics	Usongshine Nema 17 Stepper Motor (17HS4023)	STEPPER ONLINE Nema 17 17HS08-1004S	SIMAX3D Nema 17 Stepper Motor (17HS4401)
Polarity	Bipolar	Bipolar	Bipolar
Step Angle (°)	1.8 ± 5%	1.8 ± 5%	1.8 ± 5%
Voltage Rating (V)	4.1	3.7	2.8
Current Rating per Phase (A)	1.0	1.0	1.65
Winding Inductance per Phase (mH)	3.2 ± 20%	4.5 ± 20%	3.2 ± 20%
Holding Torque (N*cm)	13	16	31.38
Detent Torque (N*cm)	1.2	-	2.2
Price (\$)	9.98	10.99	9.96

Table 10 - Stepper Motor Comparisons

### *Summary*

The stepper motor that was decided on was the STEPPERONLINE Nema 17 Stepper Motor (17HS08-1004S). It was chosen instead of the others because it offered the smallest size with a reasonable amount of holding torque which when the motor is turned on will make it easier to rotate the window film. The other important parameter was the amount of inductance in the windings of the motor. The inductance for this stepper is higher than the other two motors observed and hence this motor will be slower in its rotation versus the other motors with smaller inductances in their windings which is a negative but the smart window does not require fast rotation to make it work it just needs enough rotation.

The step angle for all of the motors observed was the same amount so this parameter was not very important in selecting the stepper motor. Also the price was an important factor but from the table above it can be seen that the difference in price between the three motors is about 1 dollar which is not significant so although being the most expensive motor, it offers the best performance for the smart window.

## User Interaction

A simple comparison was done to determine if WiFi, Bluetooth, LCD buttons, or ZigBee should be used for the user interaction device. The comparison can be seen in Figure 27 below.

	WIFI	Bluetooth	LCD	ZigBee
Good	Green			
Adverage	Orange			
Poor	Red			
Cost	Green	Green	Red	Orange
Appeal	Green	Green	Orange	Green
Ease of use	Orange	Green	Red	Red
Ease of implementation	Orange	Green	Red	Red
Energy effieency	Orange	Orange	Green	Orange

Figure 27 - Comparison of methods of user interaction

## Summary

Bluetooth will be chosen for the user interaction medium. It is easy for a customer to install, simply power on. Unlike wifi would require the user to chening wifi networks everytime they wanted to change settings on the device. Because the bluetooth module can be hidden inside of the window frame therefore it is the most appealing. Writing an android app for the project is the easiest to implement when compared to writing a website on an embedded system or using LCD drivers to create a GUI.

## Fabrication Technique

A comparison was done between each of the fabrication techniques that were previously mentioned. The comparison can be seen in Table 11.

Method	Cost	Strength	Flexibility
3D Printer	Medium	Medium	High
Plasma Cutting	Low	High	Low
Laser Cutting	Low	Medium	Low
Mill	High	High	High

Table 11 - Comparison between fabrication techniques

## Summary

For our system we are not planning any metal parts because the cost is too high and we don't need the added strength. To make the large pulley for the polarizing screen mechanism we will be using a laser cutter to cut multiple sheets of plywood and laminate them together to get the desired thickness. For other small components such as a motor mount or spacer a 3D printer will be used.

## Processor

Each of the potential processors were compared side by side in Table 12.

Unit Name	Cost	Computing Power	Integrated Bluetooth	GPIO Pins
ESP32	\$9	32bit dual core 160-240MHz	Yes	39
MSP430	\$10	16-Bit core 16-MHz	No	19
Arduino Nano	\$9	8 bit AVR 20 MHz	No	22
Raspberry Pi 4	\$40	64bit Quad core 1.5GHz	Yes	40

Table 12 - Comparison between fabrication techniques

## Summary

For this project the raspberry pi 4 is overkill and too expensive. Now that the Raspberry pi 4 is removed from the selection pool all boards have a similar price. The ESP32 not only has a 32-bit architecture and dual cores, it also has an integrated bluetooth module. This saves money because with the other devices an external bluetooth breakout board would need to be acquired.

## Mobile Application Framework

For this project we will be using React Native. React Native is programmed in Javascript, one of the most widespread languages used to date. Furthermore its main competitor, Flutter, must be written in its unique language Dart. React Native is also older and better maintained than Flutter. This means that there is more supporting documentation on its as well as debugging notes on forums.

## Power Supply

Below is a table that shows all of the studied power supplies and the comparisons between them. The chosen power supply is highlighted.

	Batteries	AC-DC Power Adapter	USB Cable
Provides Constant Current/Voltage	No	Yes	Yes
Portable	Yes	Yes	Yes
Commonly Available DC Voltages	1.2V, 1.5V, 3V, 3.7V, 9V, 12.6V	18V, 12V, 9V, 6V, 5V, 3V	5V
Commonly Available Cable Lengths	-	0.91m, 1.45m, 1.52m, 1.80m, 2.29m, 2.44m	3m or 5m
Shelf Life	Alkaline (5-10yrs) Lithium (10-12yrs) Carbon-Zinc (3-5yrs)	Does not deplete over time when not used	Does not deplete over time when not used

Table 13 - Power Supply Comparisons



## *Summary*

The power supplies were compared based on the following characteristics shown in the table and the power supply method that was ultimately chosen was that of using an AC-DC power adapter. The AC-DC power adapter provides the higher voltages needed for different components of the project while many batteries would be needed to supply the voltage needed by some components and this would be expensive and the batteries would take up a lot of space inside of the window. The AC-DC power adapter also has a larger number of available cable lengths to suit the project needs whereas the USB cable is limited to 3m and 5m depending on the USB version and these cables are longer than what is needed.

It also provides a constant voltage and current which the batteries do not provide since they deplete over time when in use and the AC-DC adapter is portable because the AC-DC adapter is lightweight and can be moved anywhere whereas batteries inside of the smart window would increase the weight and make it harder to move. The AC-DC adapter also does not have a defined lifetime in terms of shelf life when it is not in use as well as for the time when it is being used.

The general consensus is that a well kept power adapter can last for many years or even a lifetime versus batteries whose shelf life depends on the type of batteries used but they can lose charge while not in use and for that alone they can only last several years. The actual runtime of different batteries also can vary based on the application so they can also last very little if the project consumes a lot of current over time.

## **Motion and Torque Transfer**

Our group spent lots of time verbally discussing which method to use. We debated back and forth, weighing the pros and cons of each method. We ultimately determined that reliability, compactness, and ease of fabrication were the most important properties for us. Because of the pulley and belts' freedom of object placement and ease of fabrication, our system will be constructed using a method that integrates pulleys and belts.

## 4. Design Standards and Constraints

Discussing the standards and constraints that pertain to our design is very important to help us understand how to properly and safely integrate each component into our design, as well as understanding our limitations. This chapter goes into detail about the design standards that relate to our project and why we need to understand and abide by them. We then talk about all the different types of constraints that may apply to our project, and how they affect specific areas of our Smart Window design process.

### 4.1. Design Standards

This next section will talk about the various standards that are used for the development of the autonomous smart window project and it also talks about the impacts of the design choices that are made in order to follow certain standards. Design constraints are also discussed which will impose limits to our engineering design choices.

Standards are usually formal documents prepared by companies, committees, organizations, and other professional groups that specify good and proper engineering practices that should be followed and that will ensure that your project designs are consistent, compatible as well as safe and efficient for others who use them.

There are thousands of standards in the world and they are used for just about every single object that can be found and only several will be discussed for the smart window project. For some of the standards for the smart window, organizations such as the American National Standards Institute (ANSI) which oversees the standards for products and system in the United States were used as well as the International Electrotechnical Commission (IEC) which is an international organization that publishes standards for electrical, electronic, and related technologies.

Other organizations such as the Institution of Electrical and Electronic Engineers (IEEE) which is the world's largest technical professional organization with its own standard association were observed for published standards for the smart window project. Many of the standards found are generally not free and therefore without purchase exact documentation for the standards found are not available but other sources provide brief summaries of the information found in each of the standards.

## Bluetooth Communication Standard

The bluetooth communication standard was designed to exchange data between mobile devices via a Ultra High Frequency radio. The frequency is between 2.4 and 2.48 GHz. The Standard is IEEE 802.15.1 and discribes class 1, class 2, and class 3. The range and power demands are as follows.

Bluetooth Class	Power Draw	Range
Class 1	100 mW	~100 m
Class 2	2.5 mW	~10 m
Class 3	1 mW	~1 m

Table 14 - Bluetooth Class

## The Bluetooth Protocol Stack

The bluetooth protocol stack demonstrates how the layers of code create the bluetooth standard. For our project we will be using the application layer.

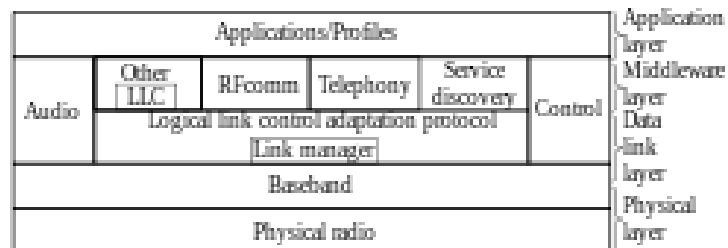

Figure 28 - Bluetooth protocol Stack  
[https://en.wikipedia.org/wiki/File:Bluetooth\\_protokoly.svg](https://en.wikipedia.org/wiki/File:Bluetooth_protokoly.svg)

## I2C Communication Standard

The I2C or inter integrated circuit communication standard allows communication though a master and slaves system. The standard requires four wires: the first Vdd which supplies a reference voltage, Sda which is the data field, Scl the system clock, and ground. The connection schematic is shown below

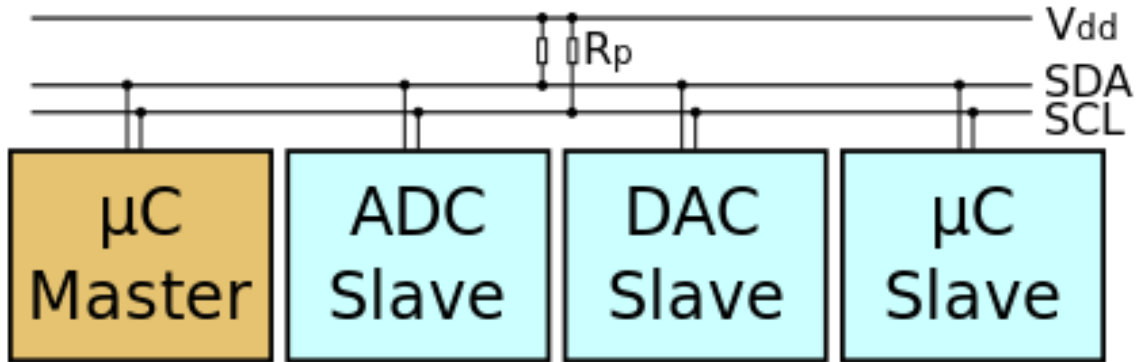

Figure 29 - I2c Configuration (<https://en.wikipedia.org/wiki/File:I2C.svg>)

The I2c has multiple modes which have different bit rates. The versions are as follows:

I2c Mode	Bit Rate
Original	100kBit/sec
Fast-Mode	400 kBit/sec
High-Speed Mode	3.4Mbit/sec
Fast-Mode	1 Mbit/sec
Ultra Fast Mode	5Mbit/sec

Table 15 - I2c modes and speeds

## Power Plug and Outlet Standard

IEC TR 60083:2015 is a standard that gives information about the types of plugs and electrical outlets used for households, offices and for general use either outdoors or indoors in International Electrotechnical Commission (IEC) member countries of which the United States is a part of. This standard specifically focuses on AC systems with rated voltages above 50V but not more than 440V. This standard will be used to help pick compatible plugs and sockets that are national standards in the United States which will be of the correct type as well as the correct voltage and frequency for powering of the smart window via the AC to DC adapter cable.

## Design Impact of Power Plug and Outlet Standard

The AC to DC adapter cable that will be used as the power supply for all of the electronics and photonic components of the smart window is of great importance because if it is not compatible with the electrical outlets available in the United States, then the smart window will not function correctly. Hence this standard is used and it is seen that in the United States the plugs used for electrical outlets are of the Type A and Type B varieties.

Both of these plugs can use a voltage of 120V and they both operate at frequencies of 60Hz. The type A plug is an ungrounded plug with two flat parallel pins with the neutral pin being wider than the live pin. The type B plug also has two flat parallel pins but it also has a grounding pin with a round shape. The grounding pin is also longer than the other two pins. For this project, the Type A plug will be used in our power adapter instead of the Type B plug.

## Power Connector Standard

IEC 60130-10 is a standard published by the International Electrotechnical Commission that specifies connectors for frequencies below 3MHz and connectors for coupling an external low-voltage power supply for portable entertainment equipment. This standard defines gender-based standards for higher voltage plugs such as those used in computer power supplies. In particular this standard also defines five different DC power connectors which will be used and they are labeled by type and they also display the specific dimensions of the inner and outer diameters of the connectors.

The types available for use are: Type A: 5.5 mm OD, 2.1 mm ID (with optional screw lock), Type A: 5.5 mm OD, 2.5 mm ID (with optional screw lock), Type B: 6.0 mm OD, 2.1 mm ID, Type B: 6.0mm OD, 2.5mm ID, Type C: 3.8 mm OD, 1.4mm ID, Type D: 6.3 mm OD, 3.1 mm ID, and Type E: 3.4 mm OD, 1.3 mm ID. For this project, these are the types of DC power connectors that will be commonly available on the market so one of these types of connectors has to be purchased to connect the power adapter to it.

## Design Impact of Power Connector Standard

This standard will help in picking a DC power connector with the correct dimensions which will be used to provide power to the PCB board. In particular a Type A DC power connector was chosen and this Type A connector is the one with an outer diameter of 5.5mm and an inner diameter of 2.1mm because our power adapter requires those same dimensions in order to be compatible. The

optional screw lock that was mentioned in the standard will not be purchased with the connector.

## IPC-2221, Generic Standard on Printed Board Design

IPC-2221 is a standard developed by IPC which is a trade association that is accredited by ANSI which publishes widely used standards in the electronics industry. IPC-2221 contains information on the generic requirements for printed circuit board design. This standard mainly focuses on printed circuit boards developed using organic materials or organic materials mixed with inorganic materials which include metal, glass, ceramic, and other materials. The documentation for this standard goes into detail on design aspects including board type, material selection for the PCB, component and assembly issues, thermal management, holes and interconnections, routing considerations, as well as electrical properties and quality assurance considerations for PCB boards.

### Design Impact of IPC-2221

IPC-2221 will provide information on proper PCB design needed to design the custom PCB for the smart window project. Proper routing considerations from this standard will be followed namely keeping the angles of the routes between components at less than 90 degrees and ideally closer to 45 degrees to minimize noise in the PCB or else signals fed through the circuit will not arrive correctly at the outputs of the PCB. Also it is advised by the standard to keep the connections between components in the PCB as short as possible in order to minimize noise as well. Not only will the noise be reduced but also the PCB will look neater and have a more organized and aesthetic appeal. This standard will also be used to decide the trace width of the routes that will be created on the PCB board.

### Light Emitting Diodes (LEDs)

IEEE has published standards for operating high-power LEDs in their IEEE Std 1789-2015. These standards have been put in place to ensure the safe and responsible use of LEDs. The primary concern for LEDs is with modulation frequency. At certain operating frequencies, the LED will flicker, potentially causing headaches or epileptic seizures to viewers. In order to prevent such effects, IEEE recommends carefully modulating the percent flicker based on the operating frequency. Figure 30 shows the results of their research, and provides a visual aid for their recommendations. Additionally, it is recommended that the LEDs only emit light in the visible spectrum since we can safely assume that these frequencies do not inherently cause harm to the human visual system.

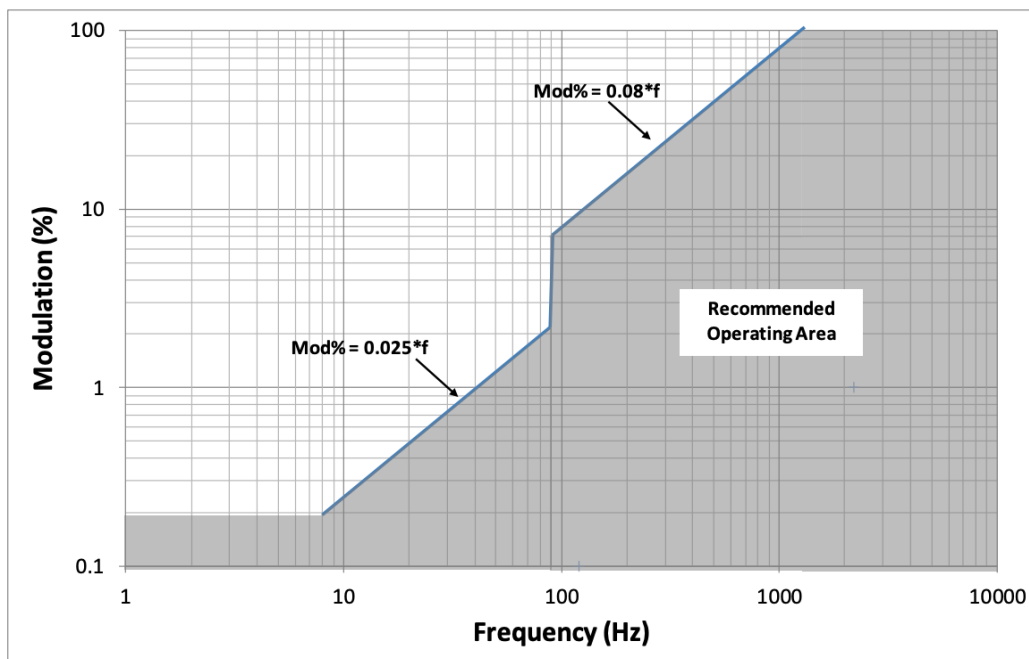

Figure 30 - Recommended operating area of flickering LEDs (IEEE Std 1789-2015)

## Silicon Photodiode Standards

Photodiodes will be used inside of our photometer to detect a range of wavelengths of incoming light on our smart window. The National Institute of Standards and Technology also known as NIST have set forth a list of transfer standards for all silicone based photodiodes. The created device uses a n-and-p junction with around a 5 nm thick oxide layer.

The oxide layer allows for increased durability to radiation exposure, especially radiation in the UVA, UVB, and UVC range. The photodiode will also use a standard through hole mount which consists of two pins and a lead wire which allows for easy connectivity to other electrical equipment.

Specifications for the silicon photodiode is an EUV calibration range of 5nm to 254 nm. They must have a usable range of anything between 5 nm all the way to 1100 nm. The responsivity of the devices is typically from 0.07 A/W to 0.27 A/W at a peak wavelength of 5 nm to 254 nm but may vary based on where the peak wavelength of the device lies.

The silicon photodiode has a range of which it can operate before reaching saturation. The range of this is called the dynamic range and changes based on the peak wavelength of light the diode is specified for. These dynamic range standards set forth by NIST are 10 pW to 10 mW. The standard active area for

the silicon photodiode is set to be 10 mm by 10 mm to ensure for the most accurate readings from the diode.

## Photodiode Optical Radiation Standards

Our smart window photodiodes will be used to detect light ranging from UVA, UVB, UVC, visible spectrum to near infrared. This classifies our photodiode as operating in the optical radiation band and therefore has its own list of standards recommended in Photodiodes - Fundamentals to Applications text.

In order to achieve the most accurate results with minimum amounts of noise we must consider how much dark current will be present in our photodiode. Operation of photodiodes used for optical radiation measurements is recommended to function under the lowest reverse bias condition possible. This allows for the least amount of noise in results.

Achieving low bias operation can be accomplished by choosing a photodiode which has epitaxial layers that are as free from defects as possible. Because we will be using a flat surface photodiode to record measurements it's also recommended to place a guard ring around the photoreceptive area which ensures that the electric field does not deviate from the photoreceptors.

When analyzing photodiodes the most important factors to consider when choosing a photodiode for optical radiation measurements are speed of response, responsivity, sensitivity, and response linearity. Using these factors is important to optimizing the function of the photodiode.

## Photometer Standards

The National Measurement System for radiometry has set forth a list of standards for photometry and radiometry. Because we will be focusing on radiometry which is the measurement of all light in the spectral region we will be focusing solely on the standards provided for radiometry.

The standard means of which to measure the power also called radiant power is to measure the power incident on a surface, in our case that surface will be the first polarizer. There are two main means of measuring radiant power, one of which is the source intensity which factors in the angle of which the emitted source is incident on the photometer along with the direction from where the incident light is coming from. The second method which we will be using is the total amount of flux or incoming light received from all directions.

Measurements for all of the different units is with respect to the incoming wavelength of light which is denoted earlier in the paper as  $\lambda$ . The chart



below has been created to easily understand all the units necessary to calculate radiante power.

Name	Symbol	Measurement
Flux	$\Phi$	Watt
Irradiance	E	Watt / (Meter <sup>2</sup> )
Radiance	L	Watt / (Meter <sup>2</sup> x steradian)
Intensity	I	Watt / steradian
Spectral Flux	$\Phi(\lambda)$	Watt / nanometer
Spectral irradiance	$E(\lambda)$	Watt / (Meter <sup>2</sup> x nanometer)
Spectral radiance	$L(\lambda)$	(Watt x Meter <sup>2</sup> ) / nanometer x steradian)
Spectral intensity	$I(\lambda)$	Watt / (steradian x nanometer)

Table 16 - Radiant power measurement standards

The impact of this table will provide us with the necessary units of measurement to compare our results with previous studies on radiometric properties of the sun. These standards of units will be invaluable to us as they give us a standard of measurement for comparison of our window design to other forms of light wave blocking instruments. By using these different units we will be able to determine exactly how effective our energy efficient smart window is.

## Photometer Design Impact

The photometer will require its own input power and an arduino board in order to read the output voltage and/or current of the diode. The circuit board used will have to be within 2 inches in width in order to ensure that it fits inside the frame of the window.

The diode itself must be placed at the bottom or top of the first polarizer. This will ensure that the diode has access to incident light from the sun so that it will work at all parts of the night and during the day. The diode must receive a small

amount of reverse bias voltage in order to function and will require our DC input power to provide this small amount of voltage. Therefore the main PCB must be built in such a way to incorporate reverse bias voltage to the photodiode along with receiving readings from the arduino board that reads the photodiode.

The arduino board that reads the photodiode must be able to do some small calculations including, calculating the flux, radiance, and spectral radiance based on equations that have been provided in the photometer design section of this document.

## Passive Infrared Motion Sensor Standards

In order to ensure the safe function of Panasonic passive infrared motion detectors, Panasonic has released a set of standards to ensure safe practice when using their device.

The passive infrared sensor is built to detect a specific wavelength that humans emit however due to the wavelength of light being a range of values to ensure detection of all humans there is a possibility that the detection of small animals, sun light or car lights could falsely trip the sensor, although this is rare it does occur as this is not a fool proof method in motion detecting.

The detection of objects can be hindered when glass, acrylic, metals, or other materials are placed in front of the sensor. This can prevent the sensor from functioning properly, blocking the necessary thermal heat signatures from reaching the sensor. In order to ensure optimal detection the standard plate that can be used to protect the sensor should be made of polyethylene or high density polyethylene.

All testing of the sensors was accomplished using a moving object that traveled at one meter per second. Therefore objects moving faster than this are not guaranteed to be detected however no detection of objects moving at a reasonable speed is highly unlikely.

While the distance provided by the manufacturer is 10 meters this is under ideal circumstances with temperatures of the human and the environment selected to ensure maximum detection. The actual max detection area may be slightly more or less depending on the temperature of the human passing, and the temperature of the environment.

The sensor should only be hand soldered at a temperature no higher than 350 degrees celsius. The sensor also requires shielded cables in order to prevent false detection from wire noise. Finally if dirt or other materials is transferred onto the lens no chemicals, rags, or paper should be used on the lens. This will cause damage to the thin polyethylene lens that is used for increased detection

distance. Instead to clean the sensor compressed air should be the only item used, if damage to the lens occurs the device is considered dead and cannot be used as its intended function may no longer work.

## Passive Infrared Motion Sensor Design Impact

The passive infrared motion sensor will force the design of the window to include two small holes at the top of the window mount, one facing in and another hole facing out. This will allow for the passive infrared sensors to view outside of the case to detect for motion.

The passive infrared sensor also requires up to seven volts of DC power. This power will be achieved through a connection to the main PCB. Therefore we must ensure that the PCB has the ability to output enough DC power to the motion sensor along with being placed in an area that has accessibility to the circuit.

## 4.2. Design Constraints

This next section will introduce the realistic design constraints that have to be satisfied for the successful implementation and use of the smart window project. These constraints are usually imposed by customers, organizations, and outside regulations that can limit the design of the project and they can even be self imposed or dictated by the laws of nature. These realistic design constraints also help ensure that this project does not become unsafe and dangerous for users and that the general well being of society is maintained. The realistic design constraints that are analyzed for this project are:

- Economic
- Environmental
- Time
- Social
- Political
- Ethical
- Health & Safety
- Manufacturability
- Sustainability

## Economic, Environmental, and Time

Economic constraints allow for the verification and feasibility of a project and help decide if a project can be executed correctly given the financial circumstances of those designing the project. Variables such as the cost of the project are analyzed as well as whether or not a project such as the smart window can compete on the open market with similar products. All of these factors will be analyzed for the smart window. The primary economic constraint for the smart window is the budget which is currently \$470 all of which will be provided by the project members without any formal sponsorship. Although this amount is our maximum budget, efforts will be made to keep the cost of all of the components below this price.

For example project members are reaching out to custom window manufacturers to see if a circular window can be provided at no cost for the members in exchange for notoriety of the window fabrication companies. Also other project members have noted being in possession of a window already which would also reduce the cost of that component of the smart window project which is also the most expensive component. The PIR motion sensors are also being designed by project members rather than being purchased through third-parties which will also reduce the costs of the smart window.

In addition, efforts will be made to keep the cost of the custom PCB to a minimum amount and this can be done by reducing the area needed by the PCB so that it only has enough area to place all of the components but not too much to the point where space is being wasted as well as money. Reducing the PCB area also reduces space needed in the smart window encasement which means that less money will be spent in increasing the size of the window encasement if the components do not fit in the first try.

Although similar products already exist on the market, namely curtains, blinds, window films, PDLC films, as well as other companies that produce windows with variable tinting features, none of them offer the customizability that the smart window of this project offers as well as the reduced cost of varying the tint using the rotating polarizers instead of using other more advanced technologies which are also more expensive.

Other similar products also do not offer smart phone capability and control and do not have energy saving features. Therefore the smart window has a great chance to compete in the market with other similar products. Perhaps the limiting factor and tradeoff to the smart window's performance on the market would be its circular shaped design. Most windows used in houses and businesses are either square or rectangular and circular shaped windows are not the norm in most cases but this is one of the tradeoffs for a lower cost. The circular shape would

also increase its manufacturing cost as well as its installation cost due to it not being a common window type seen in homes and businesses.

Of course, there are economic limitations that prevent us from designing the window to be as advanced as we would like. One example is the way in which we are going about designing a tinting mechanism. We had hoped to find an electrically controlled tinting film that could vary its transmittance by controlling the amount of input current. Such tinting films do exist, but are extremely inaccessible to the general public. Some companies, such as Continental Automotive, have designed windows for automobiles that have the capability to dynamically tint based on the surroundings of the vehicle, and the changes in the darkness of the tint occur almost instantly as the window is subject to more or less incident light. Having such a convenient solution would have been easier to implement, required fewer moving parts, and would have provided a much more technologically advanced and sophisticated feel to the tinting feature.

Another major economic constraint is severely hampering our ability to construct the window in a standard window size. Despite our window being circular instead of the standard rectangular shape, we would have still liked to make our prototype at least 2 feet in diameter. Having a larger window size would make the final demonstration more convincing and easier to witness.

But, unfortunately, increasing the window size would not only increase the cost of the window itself. A larger window area would require us to purchase 2-3 polarizers of larger size, a larger PDLC privacy screen, more LEDs, and would require more electrical power to operate the window. All of these additional costs could easily double our budget, which is already expected to be fairly high for a non-sponsored project.

Environmental constraints consider how a project design might impact the environment around it due to both its manufacture as well as its disposal. These constraints also limit the materials used on certain projects in order to protect the area where it will be placed as well as the living organisms in the vicinity. The main material used in the fabrication of the smart window would be glass which is a mixture of sand, soda ash (sodium carbonate), and limestone (calcium carbonate) all of which are naturally available in the environment and none of them are radioactive in any way and the final product is also not toxic in any way. Glass is also very beneficial for the environment because it can be recycled after being disposed of.

The process of creating new glass usually involves adding broken and recycled glass called cullet to the mixture of sand, soda ash, and limestone mentioned previously and melting it to form new glass products. To add to that, glass is a material that can be recycled endlessly and it will not lose its quality. Also recycled glass can be used for up to 95% of the raw materials found in the environment making it a safe option for the environment. However producing

glass has the negative side effect that when it is produced, combustion of natural gas and fuel are required which lead to the emission of carbon dioxide in the environment which is a greenhouse gas.

In addition to carbon dioxide, sulphur dioxide from the fuel as well as the sulphate that is decomposed by the materials can lead to acidification of soil and freshwater ecosystems which could be harmful for crops as well as for wildlife in these areas. Nitrogen oxides due to the decomposition of nitrogen compounds in the materials used to make the glass also contribute to acidification as well as smog in the air which also can be harmful. Therefore emphasis will be made towards recycling of the smart window when it is damaged and can no longer be in use. The electronic components as well when taken to the proper locations can be recycled and used for other purposes in order to reduce the dangers of producing the smart window to the environment.

Another environmental constraint that must be noted is the noise that will be generated by the rotating polarizer mechanism. Noise is very important to the environment because it not only affects owners of the smart windows but also other people who might be in the vicinity in homes as well as businesses. Unnecessary noise can be a distraction and a nuisance to others and care must be taken to reduce the noise generated by the rotating mechanism so others are minimally affected. One way to do this would be to reduce the speed of the motors so that the transition of the window from transparent to tinted is a slower but more quiet process.

The main time constraint for this project is going to be the presentation date which is currently not scheduled yet but will be planned for the end of April 2021 at the end of Senior Design 2. The time available to work on the project will be limited from the start of Senior Design 1 which began in August 2020 to the end date specified previously which gives the project team members around almost 9 months to work on the smart window. During these months research on various electronic and photonic technologies will be completed and electrical schematics as well as the phone app layout will be completed along with the PCB design, as well as the window design itself.

The ordering of parts as well as prototype design will also be completed during this time to ensure that the design specifications can be met in time and also to correct any errors that may result in the first design of the smart window. More information for the different milestones that will be achieved is documented in the Milestones section of this report along with the dates of when each task must be completed to ensure progress is being made.

## Ethical and Political

Ethical constraints exist to ensure that codes of conduct and standards are being followed and that proper behaviors and interactions are taking place during the development and implementation of this project. In order to ensure that what is correct is being done the standards mentioned above will be observed to the letter to ensure that safe designs are being implemented especially for the power plug, outlet, and PCB parts of the project since direct interaction with electrical power is being observed which could cause harm.

Another area of ethical concern that is big right now is user and data privacy. With the use of our smart phone app, user preferences for lighting will be recorded and this information is meant to be private to users only unless consent is given that it can be used by other people. For the project, team efforts should be made so that the data stored on the app cannot be accessed by foreign entities, other people using the app, hackers, or by the project team members themselves which would be a breach of privacy and lead to a possible lawsuit from the customers to the project team. If we were to use image capturing cameras to act as light sensors, then we would have to be very careful about the sensitivity that comes along with that territory. However, since we do not intend to incorporate any sensor that can capture images, we are free from such constraints.

Political constraints are necessary to understand how an engineering design relates to government regulations and political processes and how they can cooperate with one another in the real world. As of right now, we have not run into any political constraints since the purpose of our window is solely to meet the aesthetic and economic needs of homeowners. Since our device will not be excessively dangerous or intrusive, there should not be many political concerns.

## Social, Health, and Safety

Health and safety constraints are necessary in order to design products that will not cause any harm to users and they also ensure that the degree of risk of any design is well within reasonable margins. Meeting these constraints does not guarantee that a product might not fail or that it could not hurt somebody but they assure that all is done in order to avert these dangerous events. The most notable danger that could be observed for the smart window would be exposure of the electronic components which could lead to electrical shock and even possible death.

To take care of this issue all of the electronic and photonic components will be placed inside of the window frame away from the field of vision of users. Interaction with the window will also be handled through the phone app and will

not require the users to deal with any of the electrical and photonic components inside of the window frame.

Another possible danger is electrical component failure due to possible thunderstorms in the nearby area. Lightning strikes near homes can cause power surges in cabled electronic components including the smart window which could create increases in current which lead to more damage to the components in the window due to the heat generated. The heat generated due to the power can also cause the components to combust which would be a fire hazard to users in homes. Power surges like these could also be dangerous to the users of the window and lead to electrical shock if in contact with the smart window during one of these power surges, therefore the best practice recommended for users would be to disconnect the smart window during thunderstorms and to provide warnings to not supply more power to the smart window than necessary in order to avoid fire hazards.

Another health and safety aspect to be kept in mind is that of the rotating polarizer mechanism to change the tinting of the window. The rotating polarizer mechanism if improperly designed could lead to someone getting hurt because there are rotating mechanical parts but one way to ensure that this does not become a big issue is to limit the speed of the motors and hence slow down the rotation of the polarizers so that there is no potential danger to users of the smart window. The speed of the rotation however should still allow for a quick change of the tinting of the window so that users do not have to wait for a long time but also large voltages and current should not be supplied to the motors so that they do not malfunction in the process.

To elaborate on the importance of being considerate to the inhabitants of one's surrounding environment, we must take into account visual effects of our window that may potentially disturb animals or passerbys. This consideration prevents us from equipping our window with a very high reflectance outer film. Although we may, at times, want to decrease the amount of sunlight entering the window, we do not want to reflect the sunlight back into the vicinity of other people.

If the window is too reflective, the reflected light could enter the eyes of someone walking or driving by, which could be dangerous in many ways. Additionally, we must be careful about how bright our LEDs are. Since they may need to be mounted on the outside of the window, having LEDs that are extremely bright could disturb others if they look directly into them. If the LEDs have a flickering option, we must be careful not to allow them to flicker beyond certain frequencies to avoid causing headaches or seizures to anyone.

Besides the health and safety aspects, the window must meet certain social constraints in order to meet certain human needs. Some social design constraints include factors such as ease of use, safety and security, as well as attractiveness. One of these social constraints is that the window must provide



the privacy feature where the window tints when a person is detected within a 10m distance or the other feature where the user can frost the window on command. Humans have a basic need for safety and privacy and having these functions will provide security in the face of crime as well as provide privacy from outside viewers when it is desired.

The other feature that will help with this is the phone alert that a user would obtain if a suspicious person is detected in front of the window which would satisfy this social constraint for security of the users. Also another social constraint to meet human needs is the need to maintain health. Unwanted heat from the outside environment due to light coming in from regular windows would be detrimental to someone's health and comfort therefore the inclusion of the photometer to measure the incoming light and heat so that the smart window can adjust the light levels to control the heat would satisfy this social constraint to allow for human comfort.

There is also the social need to have the window be as attractive and aesthetic as possible for users who will purchase it or else no one will place it in their businesses or houses. To ensure that the design is pleasing to the eye all of the components will be placed inside of the encasement of the window so that no unwanted electronic or photonic components stick out on the exterior.

The attractiveness of the design will also be increased through the use of the smartphone app which will provide a more user friendly interaction with the window which is very important these days with the use of smartphone technology being more prevalent. In addition to that, the inclusion of the LEDs lining the inside the window will provide a more colorful aesthetic which users will love because customizability of the LED lights will be possible and customizability of any product makes it more attractive.

## Manufacturability and Sustainability

Manufacturability constraints are concerned with designing a product in a way in which it can be manufactured easily and efficiently without any extra costs. This constraint can include simplifying the fabrication of the components as well as choosing components that are common and easily available as well as redesigning a project so that the number of parts becomes less. For the smart window project one of the ways to make sure it can be manufactured is to pick common components that are easily found which is already being done.

The LED strips is one of the components that is easily found on most online retailers and they are easy to use and install and tutorials are available everywhere on their use and operation. Other components such as the L298 motor driver that will be used also are easily found and many tutorials already exist on how to wire them to motors and program them using Arduino. Other

components such as the PCB and the window will be sent to third party companies to construct which will aid in simplifying the design of the window since more experienced entities will make sure that the designs are quality assured.

The downside of this is that it will take time for all of these components to arrive at the same time so they must be ordered early to allow for this time delay. The PIR motion sensor is a component that will be designed by the project team which will aid in its manufacturability because it won't have to be designed by third parties so it will be a simpler design. Another manufacturability constraint that must be adhered to is finding components for the PCB that already have footprints available in order to design the PCB on common PCB design softwares such as Eagle. Components without footprints are not possible to place when designing a PCB schematic since these are necessary to create the 2-D diagrams for circuit designers to make the circuit boards so it would make the manufacturing much harder if the manufacturers cannot find what component one is trying to place on the circuit board.

The passive infrared will be designed using a simple DC circuit. The passive infrared sensor will be connected to an arduino nano board where the information will be gathered from all detections the device receives. When manufacturing the passive infrared we must ensure that the arduino nano for the motion sensor will connect with the PCB in order to send information back to the user and alert them when motion has been detected.

The photodiode will be used as the base component in building the photometer for the smart window. The biggest constraint for the photodiode is the active surface area. This is because the active surface area must be large enough to accept sunlight angles of at least 80 degrees which will ensure that the photometer is able to work at all times throughout the day not just when the sunlight is directly parallel to the smart window. The photodiode also allows for greater customizability for us when designing the window. Because the photodiode is a base component we will be able to manufacture the circuit around it based on the tight width and height dimensions we must adhere to in order to ensure the photometer will fit inside of the smart window frame.

The photometer must also contain an arduino board that has the ability to receive incoming current and make calculations based on how much current is being received to convert that to sunlight intensity. The arduino must be able to communicate effectively with the PCB which will allow us to communicate to the rotating polarizers in order to tell them what position they need to be at what time to save the most energy.

Another way to improve the manufacturability of the smart window is by making the window encasement as efficient as possible by accommodating all of the components inside. Not doing so could result in a manufacturing issue because

extra costs would be included in the design and more material would have to be used for the window frame that is not needed if the components are kept organized and small. More LED strips would be needed to line the window as well if the window encasement is not designed efficiently.

As previously mentioned, one of the biggest manufacturability constraints is a result of many components being purchased separated and from different markets. This limits our ability to accurately select which parts will work best together. For example, before deciding on what types of LEDs should be purchased, we must first purchase the PDLC screen so that we can experiment with it and discover what requirements must be met for the LEDs. Another example is how we cannot yet purchase the polarizers until the window design and rotating mechanism is finalized and fully designed.

Sustainability constraints focus on the process of development of engineering products that use resources that are available without using so many of these resources to the point where the world in the future will run out of them. The issue of whether projects use renewable resources is discussed as well as whether the product can be reused or recycled when its lifetime expires. As mentioned in the environmental constraints section before, glass is a resource that can always be recycled without any loss to its quality and performance and recycled glass is always being used to create new glass. Glass is also considered a renewable resource since sand is very abundant on planet Earth so using it for the development of the smart window will not hinder future generations from its use in the future.

In a more narrow sense, sustainability can refer to the longevity of our device and its ability to continue operating to its specifications. Constraints related to this type of sustainability can be directly related to many of the components being used. For example, the PDLC film uses liquid crystal technology. This technology has a lifetime before its performance inevitably begins to erode. The same applies for LEDs and sensors, as well as mechanical parts such as the rotating motor. In order to avoid sustainability issues, we must actively seek high quality components, and we cannot resort to using cheap, low-quality products to build our smart window. For example, we must take into account the heat that the window unit will be subject to if installed in a hot area such as Central Florida.

Since we expect that sunlight will constantly bombard the window and heat up the exterior of the device, we must ensure that any components that are subject to the natural elements must be able to withstand them. For this reason, we are making sure that the LEDs, polarizers, PDLC screen, exterior motion sensor, and photometer are all capable of operating in temperatures above 130°F and in humidity levels above 70%. These exterior components must also be able to operate in heavy rain and wind, and the electrical connections must be up to standard so that no mishaps can occur.

## 5. Hardware and Software Design Details

This section will talk about how the smart window subsystems will be designed in terms of both hardware and software. Namely for the hardware portion the motor driver, PCB, microcontroller, window, IR motion sensor, photometer, and photodiode designs will be discussed and schematics will be drawn up for these subsystems when relevant to do so. For the software design section the phone app used to control the smart window settings will be talked about and the layout for the app will be shown. Relevant codes will also be discussed for controlling the motors using the motor driver and for controlling the LED strips as well as for interfacing with the bluetooth module and other components.

### 5.1. Schematic of Window Design

The window of this system will consist of a 12 inch diameter circular pane of glass. There will be two panes of glass on the interior and the other exterior making it a double pane window. Double pane windows allow a section of air to act as insulation between the interior and exterior. The window frame will be 18 by 18 inches and 2 inches in depth. It will feature a circular hole in the middle where the window pane will be fixed.

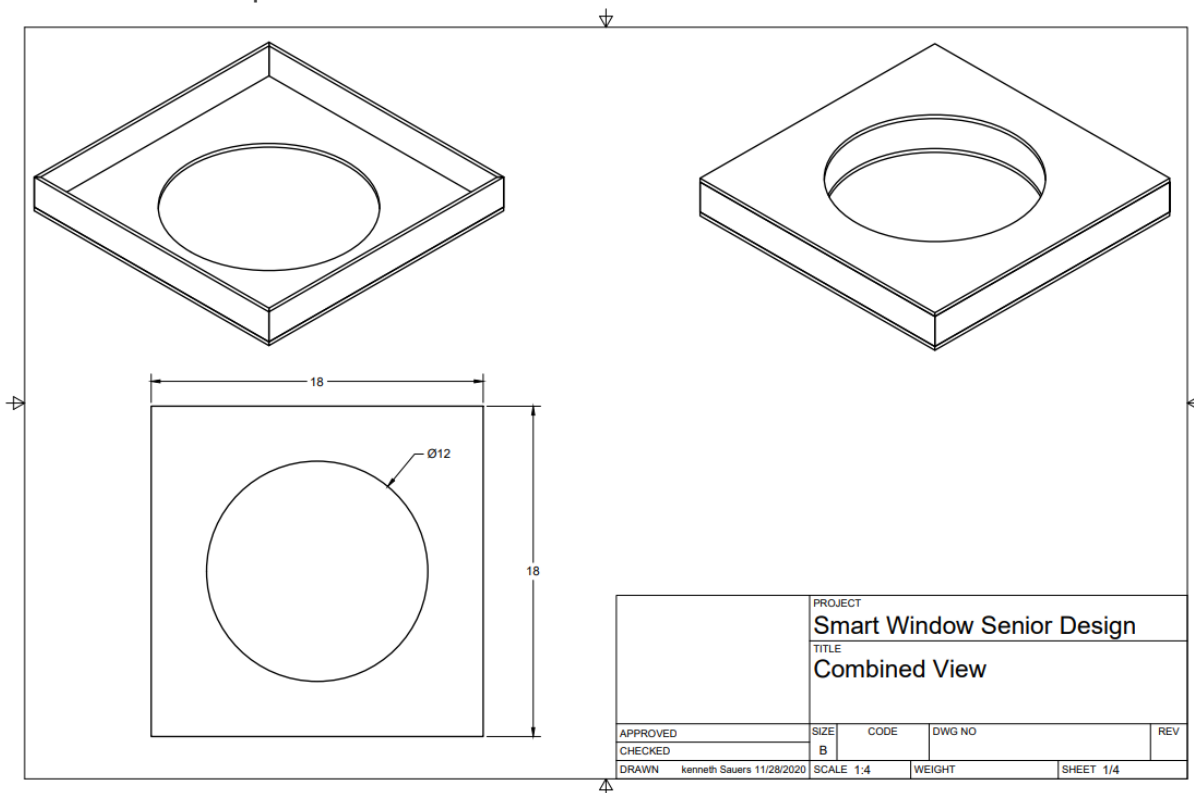

Figure 31 - Smart Window Frame View

## 5.2. Software Design

### Mobile App

The mobile app will be used to control and edit the settings of the smart screen system. When the app opens the first thing it will do is check for a bluetooth device. If the device is connected to the smart window system it will proceed to the system info page. If the user's mobile device is connected to a non smart screen or if not connected to any device it will prompt the user and open bluetooth settings on their mobile device. The flow of this application is illustrated by Figure 32.

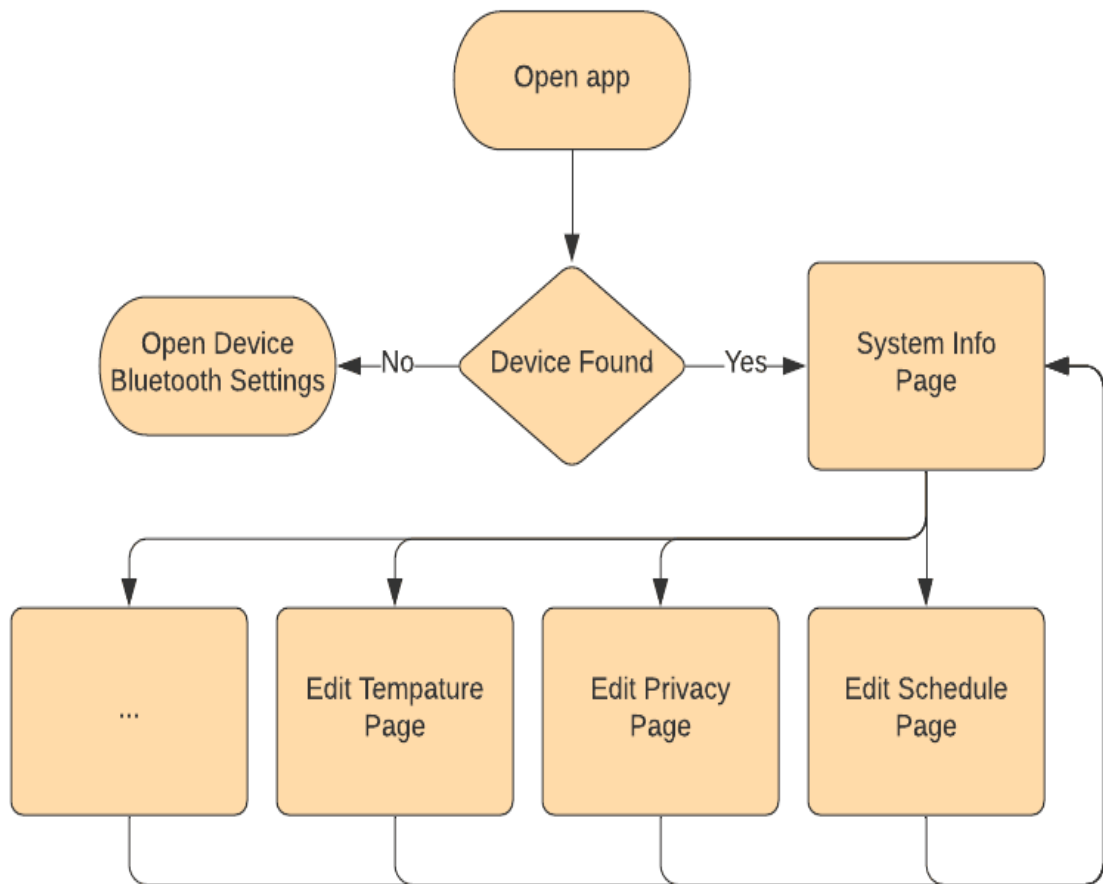

Figure 32 - App Flow Chart

## The System Start Page

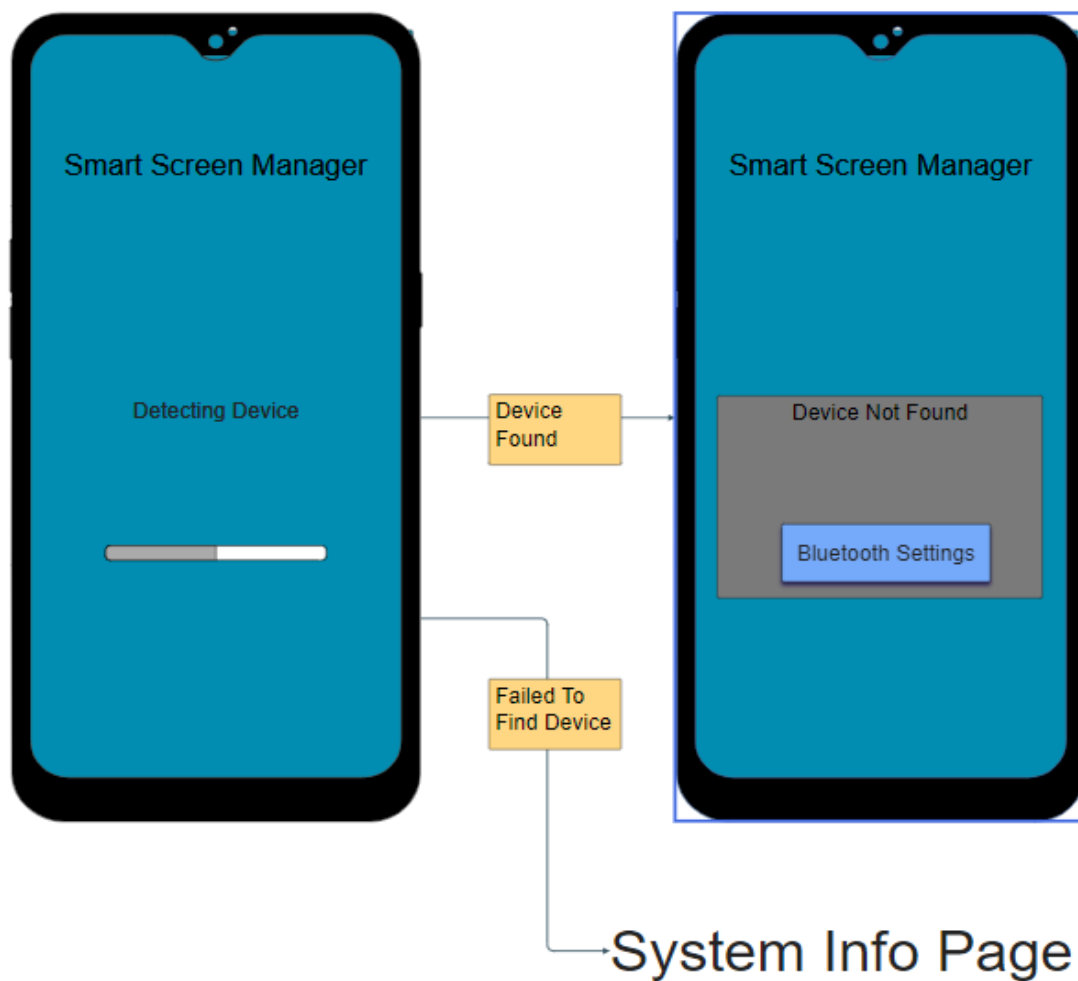

Figure 33 - App Detecting Bluetooth Device

The system start page will be used to detect which bluetooth device the mobile device is attached to. If the device is the Smart Window, the app will continue by moving the user to the System Info Page. If a differing device or no bluetooth device is connected, the app will display a failed to find device message. The user will then be prompted to open their mobile devices bluetooth's settings page. Once the user connects to the Smart Windows, the app will continue to the System Info Page.

## System Info Page

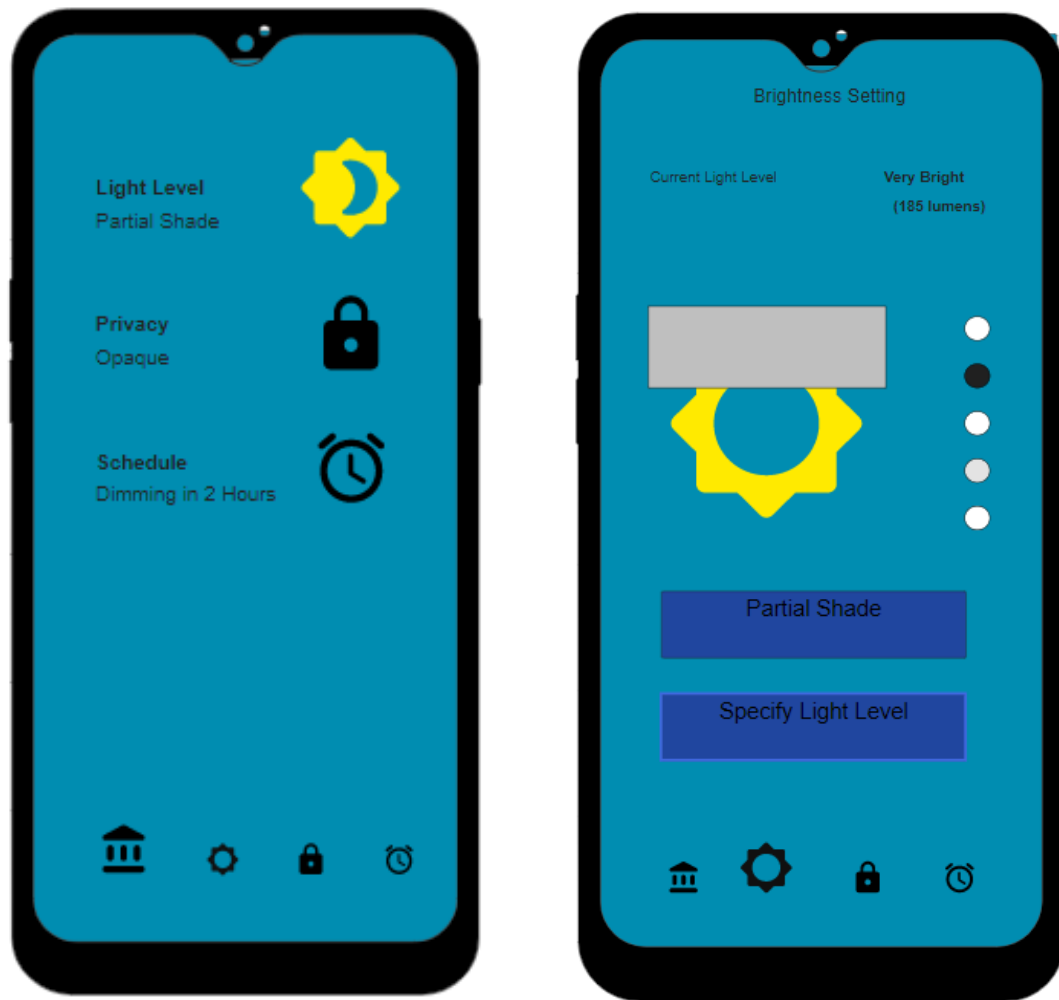

Figure 34 | 35 - System Info Screen | Brightness Settings page

The System Info Page displays the current settings of the smart screen system. It will display key settings such as the current photometer reading, whether or not the privacy screen is inactive, and if and when the system will change according to schedule. This page is read-only as it will not allow the user to change settings, but rather view the setting in one collective page. The icon bar is located at the bottom of the app on each page. This bar allows the user to select another page and show further information. The icon for the System Info Screen on the far left.

## *Brightness Settings Page*

The Brightness Settings page provides further information regarding light levels and shade as well as allows the user to instantly change the shade level of the system. At the top of this page, the current light level, the amount of lumens, is shown. Below, a graphical display of current system light and shade levels are shown. If the user wants to change levels, they can select one of the five brightness options to the right. When the user selects a shade level, the system will turn the polarizing filters to match the user's desired level chosen on the app. The shade level is constant despite the outside level levels.

In addition to selecting a constant shade level, this page allows the user to choose a specified amount of light to pass through. For example, if the user specifies 185 lumens, only that amount will pass through the window. If the light level outside is greater than the amount specified, the Smart Screen's processor will calculate the shade level required to achieve the specified light level. The system would constantly update the polarizing filters such that it allows the selected amount of light through. In the icon bar, the second image to the left is the button to the Brightness Settings page.



## Privacy Settings Page

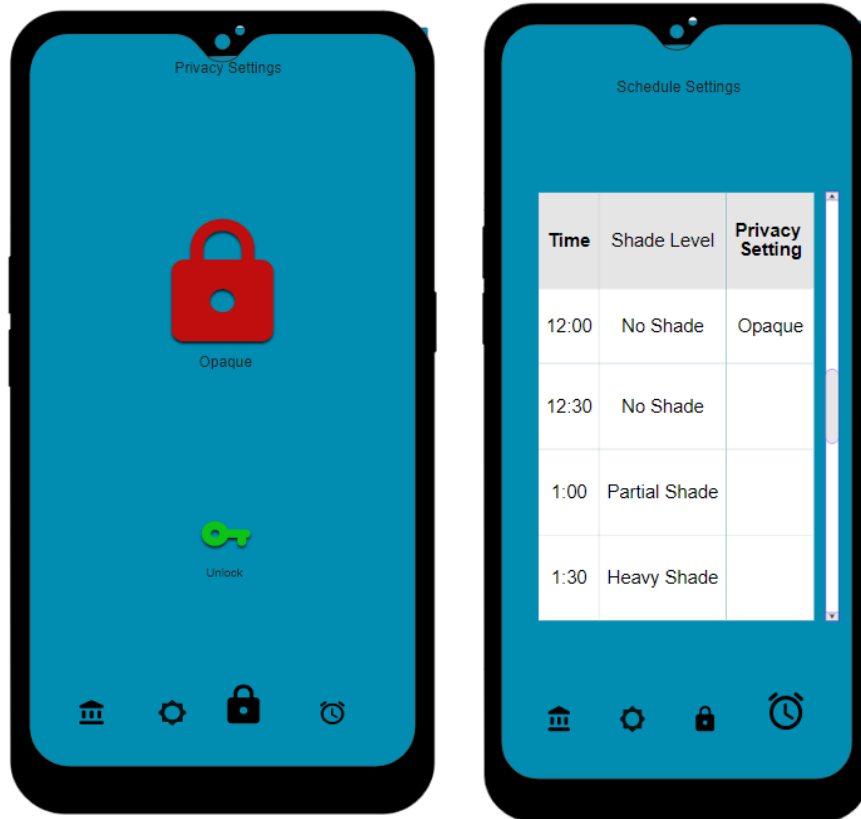

Figure 36 | 37 - Edit Privacy Page | Edit Schedule Page

The Privacy Settings Page can be found by selecting the third icon in the icon bar. This page displays two interactable symbols: a lock for the opaque option and a key for the transparent option. When the opaque option is selected, the Privacy Screen engages which give the window a frosted glass/ opaque look. This prevents outsiders from gazing at residents through the window. The key option deactivates the Privacy Screen, making the window completely transparent. The page allows the user to instantly change the windows tint level to fully transparent or opaque.

## Schedule Settings Page

The Schedule Setting page allows the user to schedule when the Smart Screen will automatically change settings. The user can access this page by selecting the last icon in the icon bar. When on this page, the user will see a table which illustrates time increments, shade levels and privacy settings. The function of this

page is to automate the functions of the Smart Window System. This feature will benefit users who follow a schedule and want the system to work without manually changing the setting each time. For example, if a user knows they will leave the house everyday from 9am-5pm, the Smart Screen can engage the privacy screen and disengage once they return. This way, no one may look inside of the residence and the light entering will be minimized while the owner is away.

### 5.3. Power Supply System

The power of the smart window will be supplied through an AC-DC adapter and this adapter will produce a 12V DC output voltage. This 12V output voltage will be supplied from the plug to a power jack which will be connected to the PCB board and will power all of the components of the window. However not all of the components in the window require the same supply voltages to operate.

Namely the Arduino Nano that will be used to connect to the photodiode will require a 5V input voltage and the ESP32 microcontroller board that will connect to the IR motion sensor will require a 3.3V input voltage as well. Therefore the power supply system will include two voltage regulator circuits that will be used to step down the voltage. One of the regulators will produce a 5V at its output and the other will produce a 3.3V regulated output voltage and the design of these circuits will be shown along with the schematic of each.

#### 5V Linear Voltage Regulator Circuit

The Eagle schematic capture and printed circuit board layout software was used to design all of the circuits for the smart window project. In order to design the 5V regulator, common voltage regulators were studied and one of the most common regulators was used for the smart window project namely the 7805 voltage regulator. This regulator would be relatively inexpensive and it is simple to wire since it only has three pins and it also produces the output of 5V needed. This regulator also has a max input voltage of 35V and the input of 12V will be enough to turn it on because the dropout voltage of the regulator is only 2V meaning that 7V is the minimum required voltage to maintain regulation.

However, wiring 12V to the input to get 5V at the output is not a good design choice because it offers no protection to the voltage regulator circuit. If the output voltage becomes greater than the input voltage for whatever reason then the voltage regulator can become damaged along with other circuit components in the system. To avoid this, a voltage regulator with diode protection is used so that if the output voltage becomes greater than the input voltage then the current will flow from the output to the input and will prevent current from flowing into the

voltage regulator IC. The capacitors were included to eliminate noise in the voltage signals.

The values of the capacitors were made large enough and were set to arbitrary values. As long as they were greater than the pF range, they would meet the regulator requirements. Resistor R4 was included so that the output voltage could be measured across that resistor rather than doing it across the capacitor because the voltage across the capacitor may change when a voltmeter is connected to it to measure the output voltage since the capacitor may start to discharge.

The diode was chosen to be a 1N4148 diode. This diode is very common and can tolerate large reverse voltages up to 100V before it breaks down which is necessary because a reverse voltage of 12V will be applied to it as the input of the voltage regulator. This diode also comes as a through-hole component and can be easily tested on a breadboard. The 5V regulator circuit designed can be seen below.

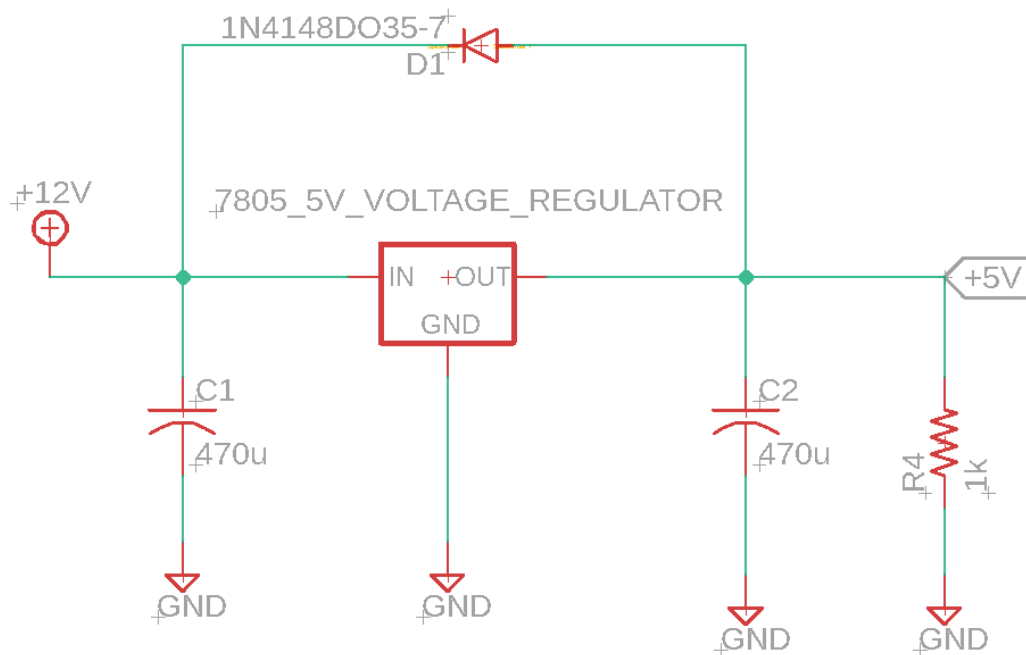

Figure 38 - 5V Linear Voltage Regulator Schematic

### 3.3V Adjustable Voltage Regulator Circuit

The 3.3V voltage regulator circuit was designed differently from the 5V regulator. This is because the same 7805 regulator could not be used because the voltage

could not be adjusted below 5V at the output to get the 3.3V needed. Therefore the LM317T voltage regulator by Texas Instruments was used because its output voltage could be adjusted by using resistors and voltages in the range of 1.25V to 37V could be obtained and input voltages of 4.2V to 40V could be applied at the input. Two resistors labeled R2 and R3 were adjusted to obtain an output voltage of 3.3V. The resistors could be picked by using the equation shown below given in the Texas Instruments datasheet to obtain a constant reference voltage of 1.25V at the node between the two resistors.

$$V_{out} = 1.25(1 + R3/R2)$$

#### Equation 1 - Calculation of Output Voltage by Adjusting R2 and R3

Using the equation given, R3 in terms of R2 could be found and R2 was selected as 500Ω and R3 therefore had to be 820Ω to get an output voltage of 3.3V. The circuit schematic could then be drawn as shown below.

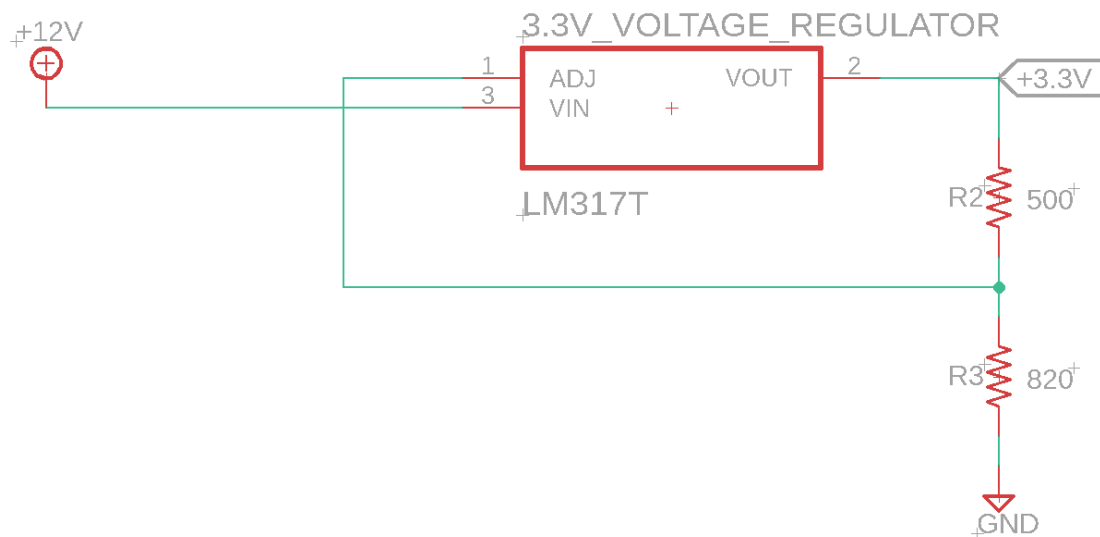

Figure 39 - 3.3V Adjustable Voltage Regulator Schematic

For the voltage regulator circuits above, the bill of materials (BOM) of all of the components of these two circuits could be created in Eagle and exported out. The BOM which includes the part designator, quantity, value, package, manufacturer, and price can be seen below.

Part Designator	Quantity	Value	Package	Manufacturer
LM317T	1	-	TO254P1054 X470X1955-3	Texas Instruments
7805	1	-	78LXX	On Semiconductor
C1, C2	2	470uF 25V	C0805	Panasonic
R2	1	500Ω	R0805	Multicomp Pro
R3	1	820Ω	R0805	Multicomp Pro
R4	1	1kΩ	R0805	Vishay
D1	1	-	DO35-7	Multicomp Pro

Table 17 - 5V and 3.3V Voltage Regulators BOM

From the components above, all of the resistors and capacitors were chosen as through-hole components to make the testing of the regulators much easier since they can be placed on a breadboard and do not have to be mounted on and soldered to anything. Also for the final PCB design, the resistor and capacitors will be much easier to install since they are generally large components and soldering them to the board will be easy.

The capacitors were chosen to support a maximum of 25V which is much larger than the input voltage of 12V that the 5V regulator will receive at the input or at the 5V output. The 5V regulator on the other hand was chosen as a surface mount component which will make the testing a bit harder. It should also be noted that the components above were all purchased together through Newark Electronics which is an electronic components distributor.

A breadboard test was done once the components for the 3.3V regulator had arrived and the results can be seen below.

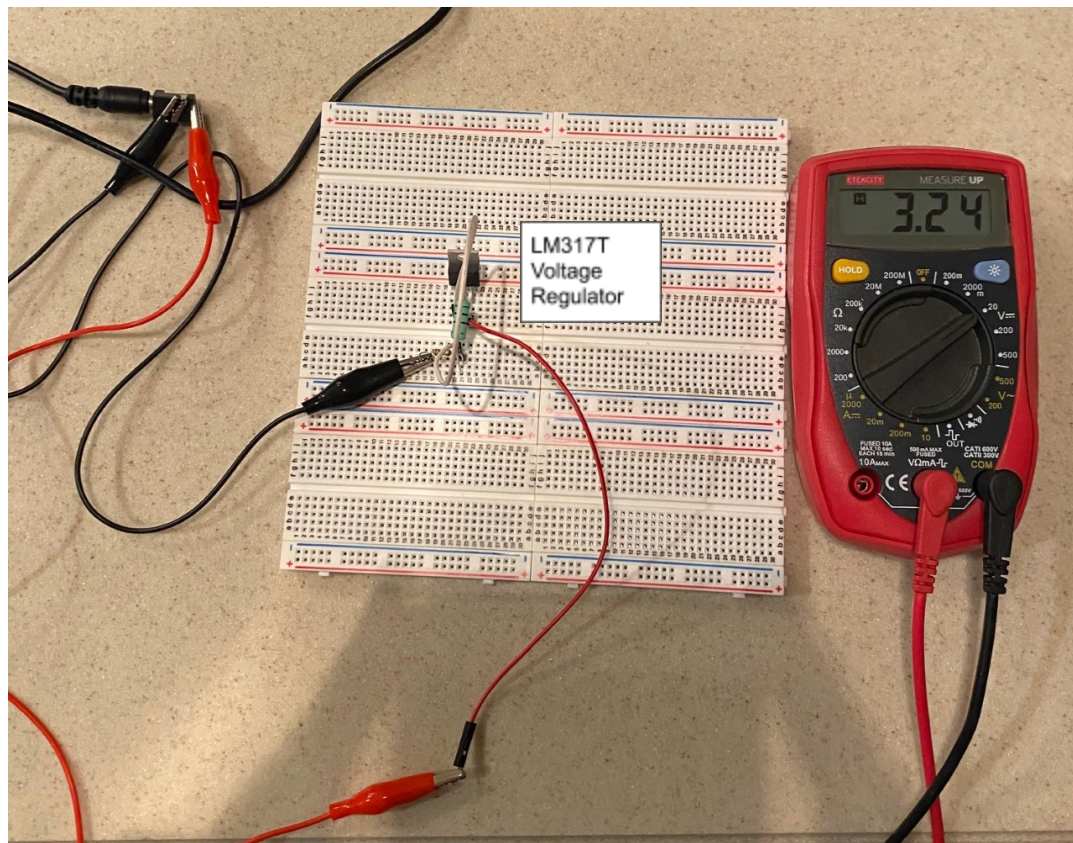

Figure 40 - 3.3V Voltage Regulator Breadboard Test

A regulated output voltage of 3.24V was measured at the output of the regulator with a multimeter so it is working as it is supposed to with an input voltage of 12V coming in from the power connector. The resistors and the LM317T used to make this regulator also did not experience a significant increase in heat which is a good characteristic.

## Power Connector Circuit

Apart from the two regulator circuits above, the power connector circuit will contain the connector that will have the power adapter plug connected to it which will be connected to the PCB board. Along with that it will also have an LED that will turn on when power is being supplied to the PCB. This will help in testing the PCB board so that it is known whether there is current flowing in the system. Along with the LED there will be a resistor that will limit the current going into the LED because a large voltage applied can cause a very large current spike in the LEDs and it can lead them to become damaged causing them to not work anymore.

To find this resistor a simple KVL equation was done using the 12V DC input from the connector and the turn on voltage of the LED. A 5mm LED with a turn on voltage of 3V - 3.2V and a required current of 20mA was already in possession so the resistor needed could be easily found using the equation below.

$$R = (V_{DC} - V_T) / I = (12V - 3.2V) / 20mA = 440\Omega$$

Equation 2 - Calculation of Resistor R to turn on LED

Therefore only a resistor of 440Ω would be needed to turn on the LED. This resistor had to be able to withstand at least 176mW of power due to the 8.8V that will be dropped across it. Instead of using a 440Ω resistor, two 220Ω resistors were used instead in series with each other and each will have a power drop of 88mW. The only other consideration for this circuit was how to connect the three terminals of the power jack. The front terminal or tip is the one that would be connected to the resistor and LED and other circuits while the other two terminals called the sleeve and the insertion detection pins would be connected to ground when the plug was not inserted. The schematic for this circuit can be seen below.

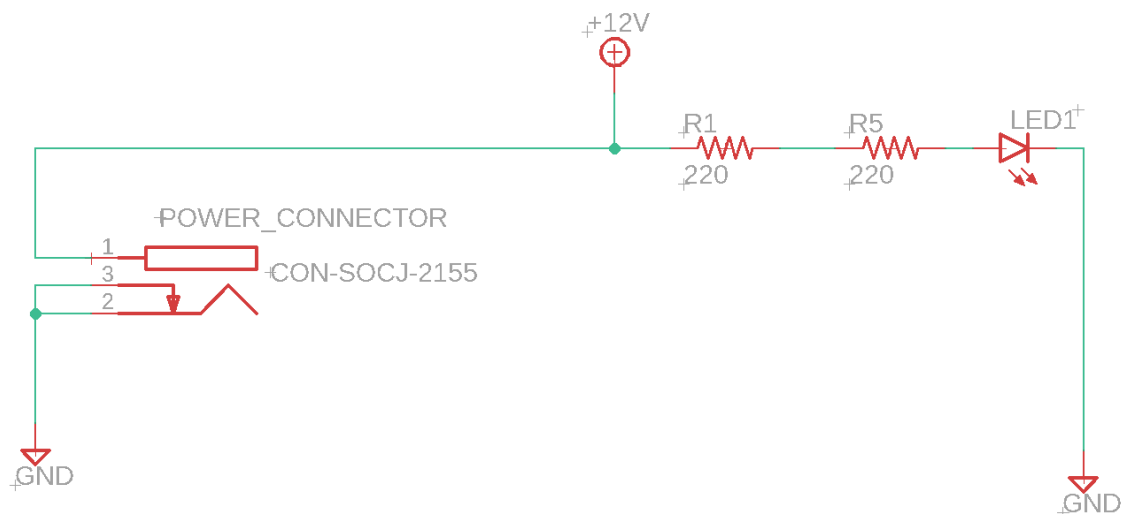

Figure 41 - Power Connector Circuit Schematic

For the power connector circuit, the BOM was also generated in Eagle which includes the component choices for the resistors, the power jack connector and the LED and the same categories as before were included in the BOM and it can be seen below.

Part Designator	Quantity	Value	Package	Manufacturer
CON-SOCJ-2155	1	-	CONSOCJ2155	Gravitech
R1,R5	2	220 $\Omega$	R0805	ELEGOO
LED1	1	-	LED5MM	DiCUNO

Table 18 - Power Connector Circuit BOM

The resistors chosen are axial-leaded through-hole resistors again and these are rated for a 1/4W each or 250mW. The LED chosen will have a diameter of 5mm and it is also through hole with two leads. The power connector is also a through hole component with 3 pins that must be soldered on the PCB board.

## 5.4. Motorized Polarizing Screen Mechanism

### Overview

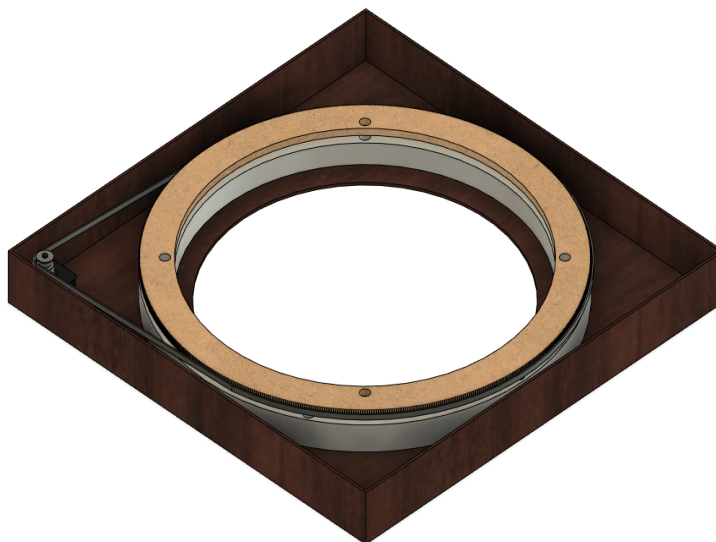

Figure 42 - Motorized Polarizing screen mechanism



The purpose of the motorized polarizing screen mechanism is to rotate one polarizing film between 0 and 90 degrees. This coupled with a fixed polarizing screen attached to a window will allow our system to control the light being passed through the window. The mechanism to rotate the film will be made up by a large diameter bearing with an inner diameter which is larger than the diameter of the glass. This is so none of the mechanism components are visible to the user. The outer portion of the bearing will be attached to the window frame thus fixing its position. The inner portion is attached to a pulley and polarizing screen adapter. This component will be driving from a stepper motor and timing belt.

## Stepper Motor

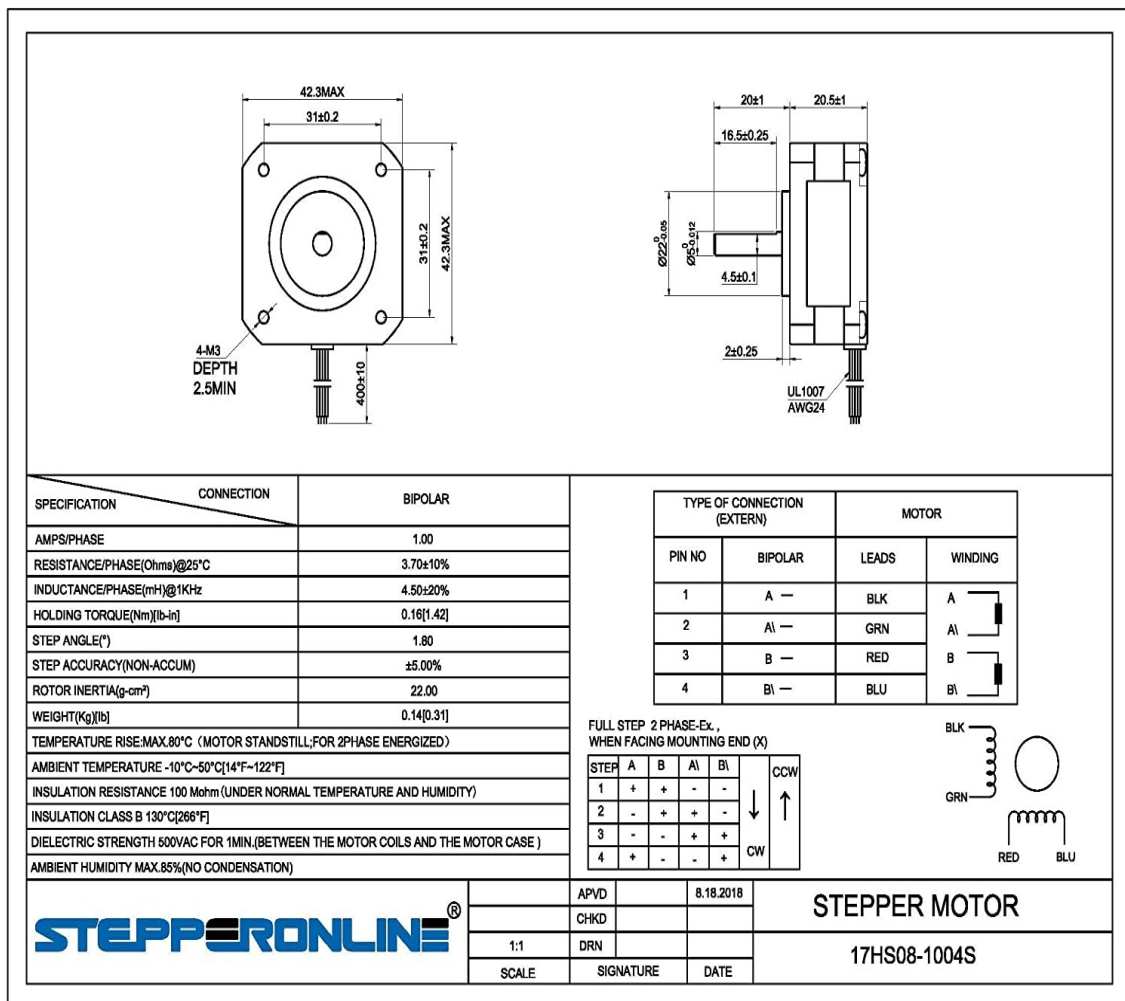

Figure 43 - Dimension for the Nema 17 Stepper motor

We chose a stepper motor for this mechanism for many reasons. The first of which is the form factor; the stepper motor features a rectangular housing which allows this motor to be fixed to a surface without the need for a complex mounting system to be designed. The smaller variants which are used are wider than tall. This allows it to fit into the window frame without making it unnecessarily thick. Another reason to choose a stepper motor is because we can estimate the rotation of the motor shaft.

## Pulley and Polarizing Screen Adaptor

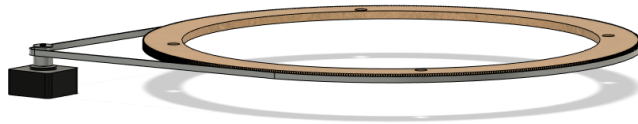

Figure 44 - Pulley and Polarizing Screen Adaptor

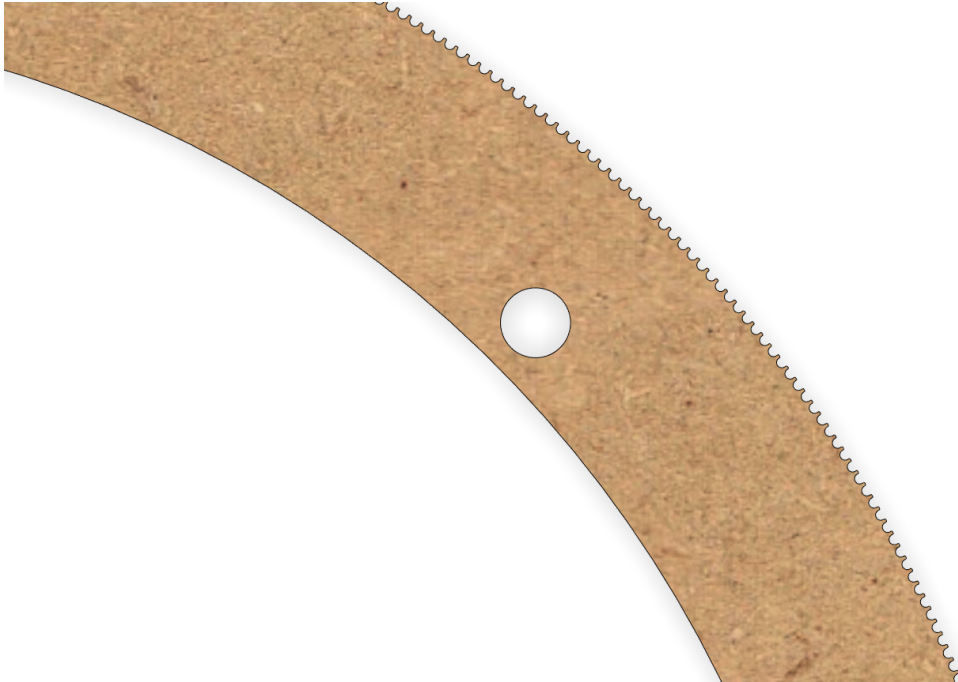

Figure 45 - Large Pulley

The pulley will be 400mm in diameter with 200 teeth. To fabricate the pulley we will laser cut multiple sheets of thin plywood and laminate them together to reach the desired thickness. When the desired thickness is achieved the pulley system will be mounted inside the window.

## Belt and Pulley

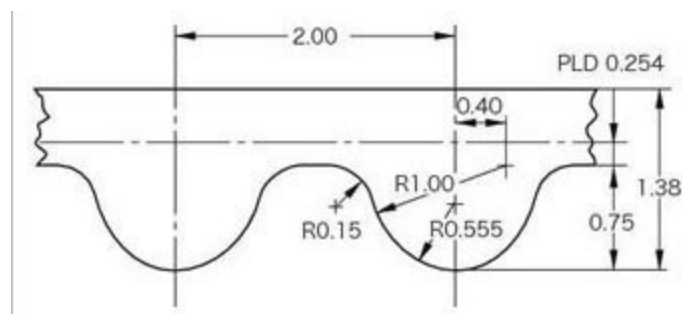

Figure 46 - GT2 belt dimensions

We will be using a GT2 timing belt which has a width of 5mm and a pitch of 2mm. This belt was chosen because of its small width. We want it to be as thin as possible so that the thickness of the window frame is as small as possible. The torque exerted by the belt system will be very low because the inertia of all the moving parts is small and the speed they will be moving at is low. Therefore, a thin belt such as GT2 is optimal.

## Conclusion

In conclusion, the system laid out above provides an accurate low cost method to rotate a polarizing film, while also being compact enough to fit within a window frame. We achieve this at such low cost by manufacturing our large pulley out of plywood. Manufacturing this gear out of aluminum or nylon would cost at least ten times as much. The bearing we will be using is intended for building a custom lazy susan. The price of a bearing with a similar inner diameter from a supplier such as mc master would be in the thousands.

## 5.5. Motor System Design

The motor system design will primarily focus on how the chosen stepper motors will be rotated using the ESP32 microcontroller board, the L298N motor driver, and the 12V AC-DC power adapter and connector. The code used to rotate the Nema 17 stepper motor will also be talked about in this section and the breadboard testing for this system will also be shown to make sure that the components work as they should. The breadboard test is shown first and can be seen immediately below.

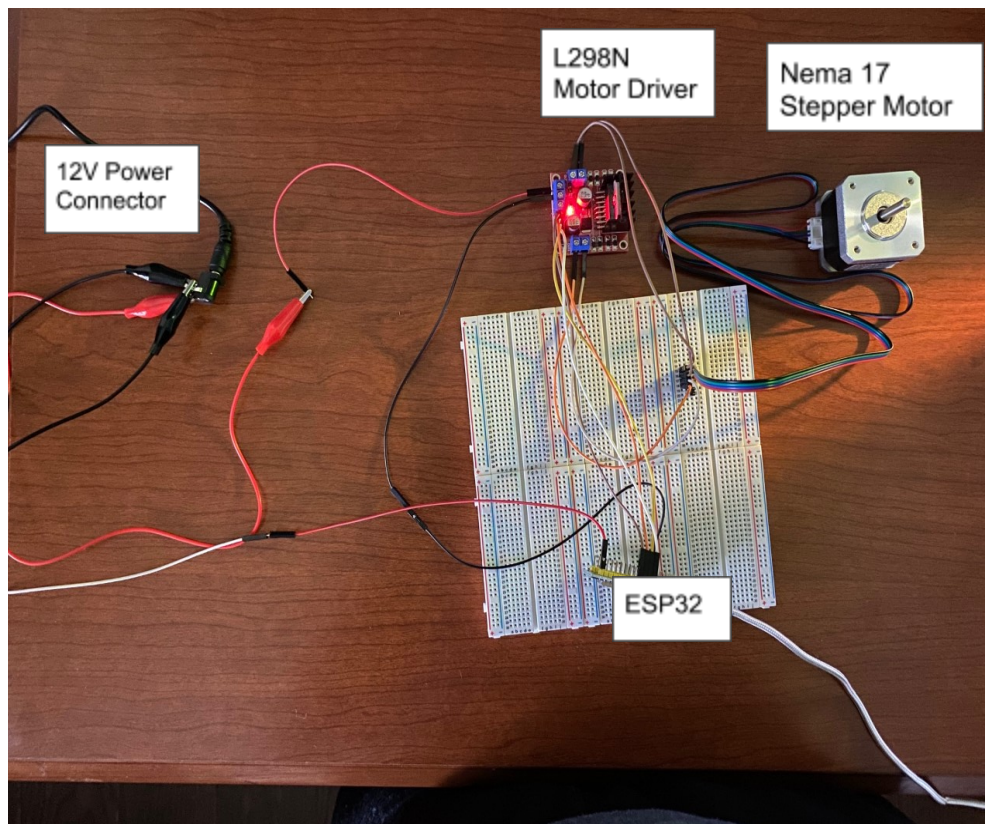

Figure 47 - Motor System Breadboard Test

## Motor System Breadboard Test

In order to make the stepper motor rotate, care was taken with the four wires of the stepper motor to make sure that the A+ and A- wires of one of the coils were connected to the OUT1 and OUT2 pins of the L298N motor driver while the B+ and B- wires of the second coil of the stepper motor were connected to the OUT3 and OUT4 pins of the motor driver. Improper wiring of the cables would result in damage to the motor coils. Through examination of the stepper motor datasheet it was found that the black and green wires would be the A+ and A- wires respectively while the red and blue wires would be the B+ and B- wires respectively.

On the motor driver end, the board was supplied with +12V from the power connector to the +12V pin and the GND pin was connected to both the ground of the power connector and the ground of the ESP32 board. The Input 1, Input 2, Input 3, and Input 4 pins of the motor driver were connected to IO pins D14, D27,

D26, and D25. The ESP32 was supplied with +5V from a USB cable from the computer in order to upload the code, but after uploading the code an external power supply of 3.3V could be used to power it since a 5V input is stepped down to 3.3V anyways to power the board. The code that was uploaded to the board would rotate the stepper motor clockwise and would set the speed of the motors to 60rpm and the only parts changed to the default code were the pin numbers used. The steps per revolution was kept at 200 due to the motor being used and rotation was observed every half second.

For the schematic design of the motor system, the L298N module would not be on the PCB board however the ESP32 would be placed on it and many male and female pin headers would be placed to attach the stepper motor to the PCB and connect all of the voltages and grounds from the PCB to the ESP32 and to the jumpers. The schematic for this section can be seen below.

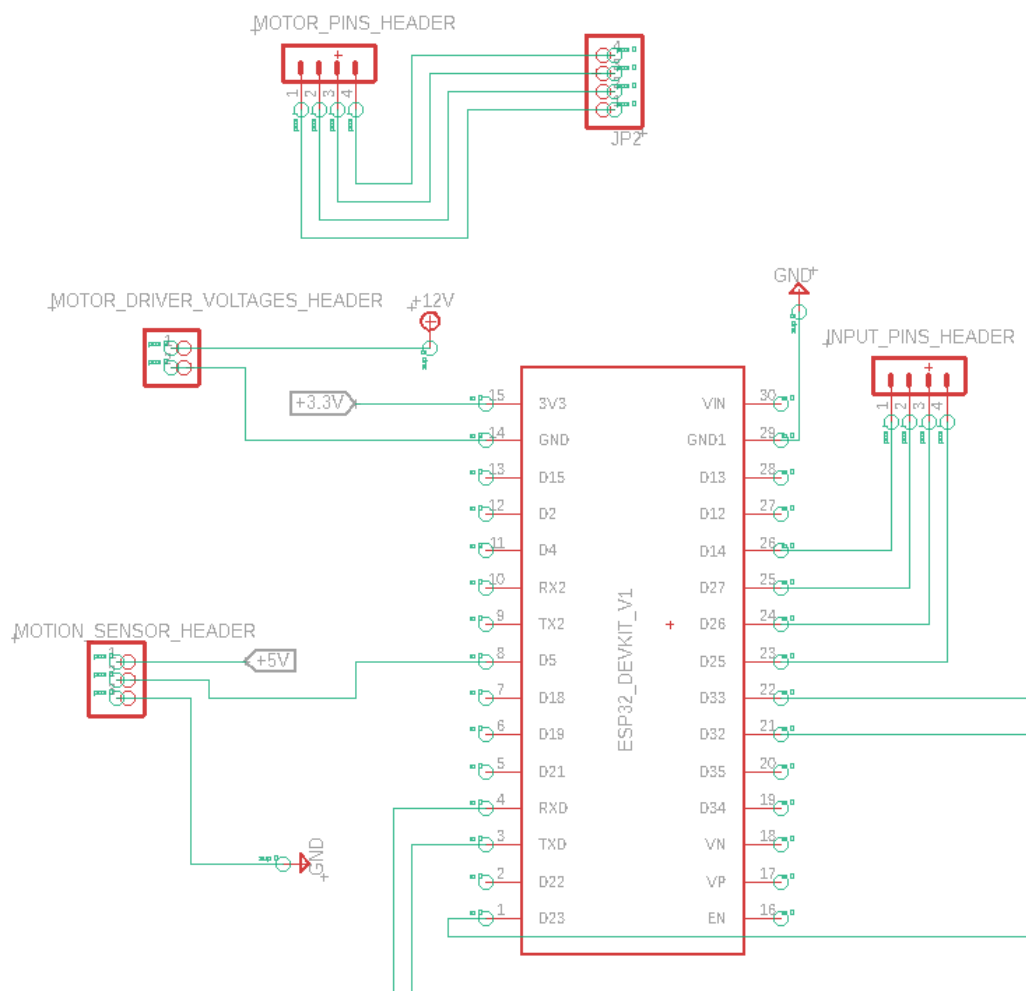

Figure 48 - Motor System Circuit Schematic

Not included in the motor system but still observed in the schematic is another pin header that will be connected to the ESP32 board on IO pin D5 along with connections to +5V and ground. This pin header will be used to make connections to the PIR motion sensor that will be used to detect objects at a distance. The PIR motion sensor chosen requires a voltage of +5V to operate hence why the output of the 5V regulator will be used to connect to it. The D5 pin was chosen because this pin supports analog to digital conversion and the ESP32 can handle ADC conversion from 0 to 3.3V.

It can also be observed in the schematic for the motor system that IO pins D32, D33, and D23 of the ESP32 are connected to additional components not shown and those are the components that will be used to control the LED strips that will go around the smart window. The additional schematic for those parts can be seen next.

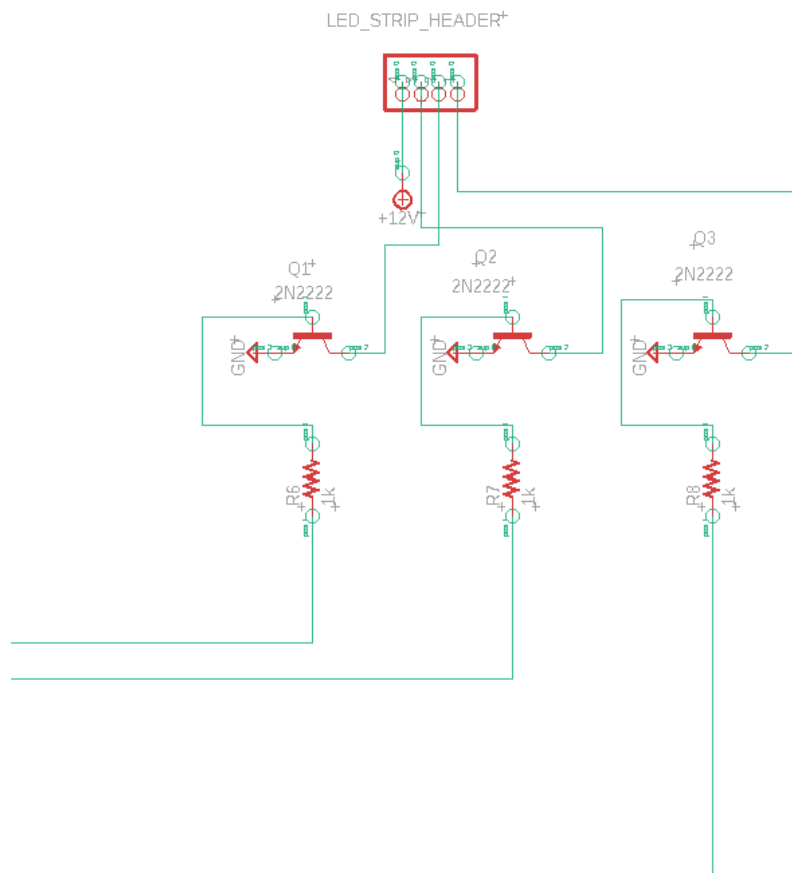

Figure 49 - LED Strip Circuit Schematic

## Circuit Design Breakdown

From the schematic above it can be seen that for the LED strips there will be a pin header with 4 pins that will be used to make connections from the PCB board to the LED strips. Most likely the 12V power supply will be connected to one of the pin header pins if a 12V strip is used but if another voltage strip is used the 5V from one of the regulators can be connected to it as an alternative if a 5V strip is used. The other three pins are each connected to 2N2222 NPN transistors which will be used to control the RGB color components of the strip.

The 2N2222 NPN transistors were chosen because they can tolerate a collector current of up to 800mA which should be enough to supply current to the LED strip at its maximum output which would be when the LED strips are emitting white light at its maximum brightness. The resistors are used to limit the current between the ESP32 and the LED strips since the base current will be amplified by the gain factor to obtain the collector current into the LED strips. The way the ESP32 will change the colors of the LED strip is by sending a PWM signal with the individual RGB values through each of the pins of the ESP32 to each of the transistors which will then go to the separate LED strip data wires.

The BOM for the motor system circuit including the LED strip circuit components can be seen below.

Part Designator	Quantity	Value	Package	Manufacturer
Q1, Q2, Q3	3	-	TO18	Multicomp Pro
R6, R7, R8	3	1k $\Omega$	R0805	ELEGOO
LED_STRIP_HEADER, JP2	2	-	1X04	Glarks
MOTION_SENSOR_HE ADER	1	-	1X03	Glarks
MOTOR_DRIVER_VOL TAGES_HEADER	1	-	1X02	Glarks
INPUT_PINS_HEADER, MOTOR_PINS_HEADE R	2	-	MA04-1	Glarks
ESP32_DEVKIT_V1	1	-	ESP32_1PRI MARY	MELIFE

Table 19 - Motor System & LED Strip Circuits BOM



## 5.6. Photodiode System Design

In order to acquire the output voltage and input current for reading the photodiode a basic equation will be used as shown below.

$$V_{out} = P_{in} * R(\lambda) * RL$$

Equation 2 - Calculation of Output Voltage using input power and load resistor

Vout represents the output voltage of FDS1010, Pin represents the input optical power to the photodiode,  $R(\lambda)$  is the responsivity and RL is the load resistor. Responsivity is the ratio of the measurement of input optical power and output photocurrent. The responsivity in a photodiode changes based on the wavelength and has been calculated and given by the manufacturer as shown below so we have the ability to calculate output voltage at every wavelength between 350nm and 1100 nm.

Measuring the output current of the photodiode based on the wavelength has been standardized across diodes. This is used to calculate how much power the photodiode itself is able to create based on the incoming wavelength of light. The formula which is recommended is posted below.

$$I(\lambda) = I_{dark} + (1 - p(\lambda)) * \epsilon(\lambda) * \lambda * \varphi(\lambda)$$

Equation 3 - Calculation of Output current

In this equation lambda is the incoming wavelength of light, I dark is the initial dark current response before incident light, p of lambda is the photodiode reflectance characteristics, epsilon of lambda is the photodiodes internal quantum efficiency rating, and phi of lambda is the spectral radiant flux that is on the photodiode.

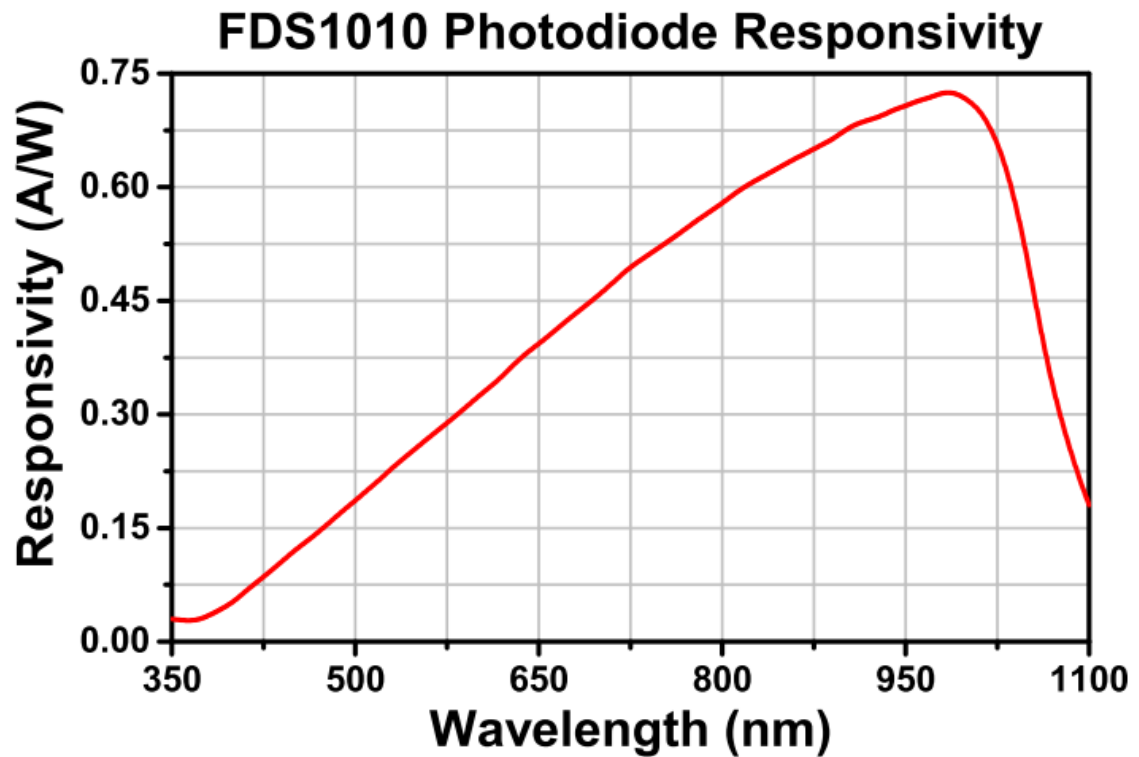

Figure 50 - Responsivity of FDS1010 graph

The graph above represents the Thorlabs FDS1010 photodiode responsivity and will be used to determine all of the output voltage readings for the diode when connected to our smart window.

The bandwidth which is used to determine the speed of response of the photodiode is an important metric in determining the time taken to record a change of input light on the photodiode. The equation used to determine this metric is listed below.

$$Fbw = 1/(2\pi * RL * Cj)$$

Equation 4 - Bandwidth calculation of a photodiode

In the equation above Fbw is the bandwidth of the photodiode, RL is the load resistor and Cj is the diode capacitor. The bandwidth is then used for calculated the actual response time of the photodiode which is in the equation posted below.

$$\tau = 0.35 / (Fbw)$$

Equation 5 - response time of the photodiode

Tau represents the photodiode response time. These calculations will be used in our testing to ensure that the photodiode we have purchased is working correctly and will function the way we need it to. A basic recommended constructed circuit diagram for using the photodiode FDS1010 is shown below.

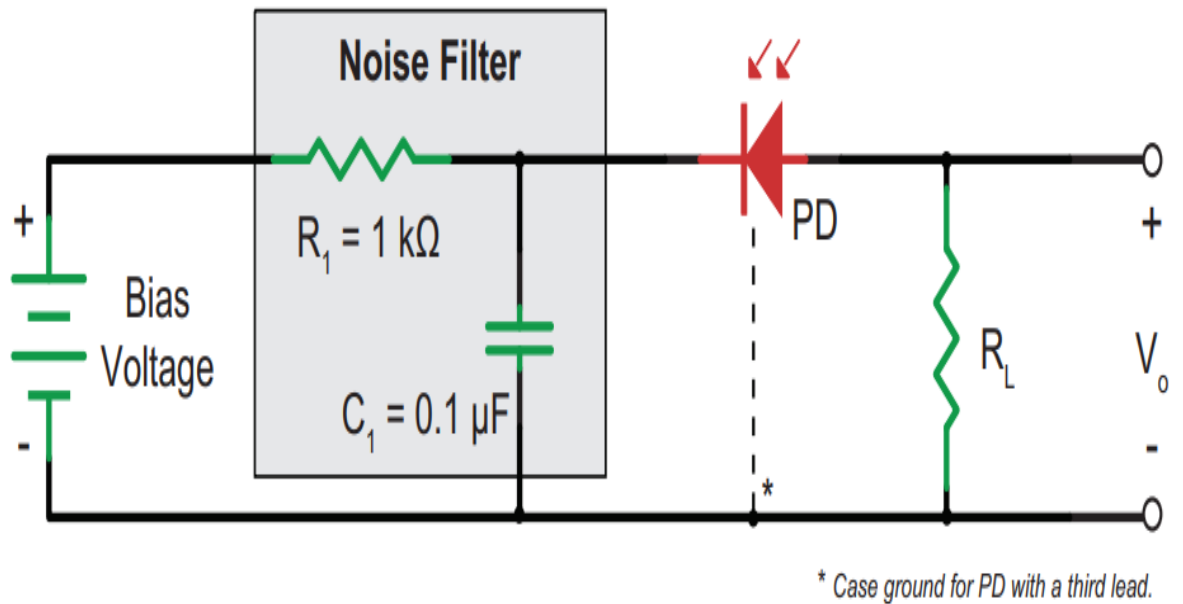

Figure 51 - Photodiode FDS1010 circuit diagram (Thorlabs circuit diagram)

The basic circuit setup above allows for customizable options if needed to achieve the desired results of the photometer which will allow us to record measurements of incoming sunlight.

## Thorlabs - FDS1010 Specifications

The photodiode FDS1010 that is being used has all of the specifications that are listed below. The second table posted below will contain the specifications for the maximum ratings the photodiode can be used at.

<b>Specifications</b>	
<b>Wavelength Range</b>	350 nm - 1100 nm
<b>Peak Wavelength</b>	970 nm
<b>Active Area</b>	100 mm <sup>2</sup>
<b>Rise Time</b>	65 ns
<b>Minimum optical power (NEP)</b>	2.07E-13 W/( sqrt(Hz) )
<b>Responsivity</b>	0.725 A/W
<b>Dark Current at 5 volts</b>	600 nA
<b>Capacitance</b>	375 pF
<b>Package</b>	Ceramic
<b>Sensor</b>	Silicon

Table 20 - Photodiode FDS1010 specifications

<b>Maximum Rating</b>	
<b>Maximum Reverse Bias Voltage</b>	25 V
<b>Reverse Current</b>	10 mA
<b>Operating Temperatures</b>	-10 °C to 60 °C
<b>Storage Temperature</b>	-20 °C to 70 °C

Table 21 - Photodiode FDS1010 specifications

The photodiode maximum rating is important information because it allows us to know the boundaries of what FDS1010 is capable of. If needed we can push the limit of the photodiode but anything exceeding these ratings has the potential to permanently damage the photodiode rendering it unusable in the future.

## Photodiode Circuit Schematic

Using the photodiode circuit diagram from before, the following schematic was created for use on the PCB board utilizing an Arduino Nano V3.0 board.

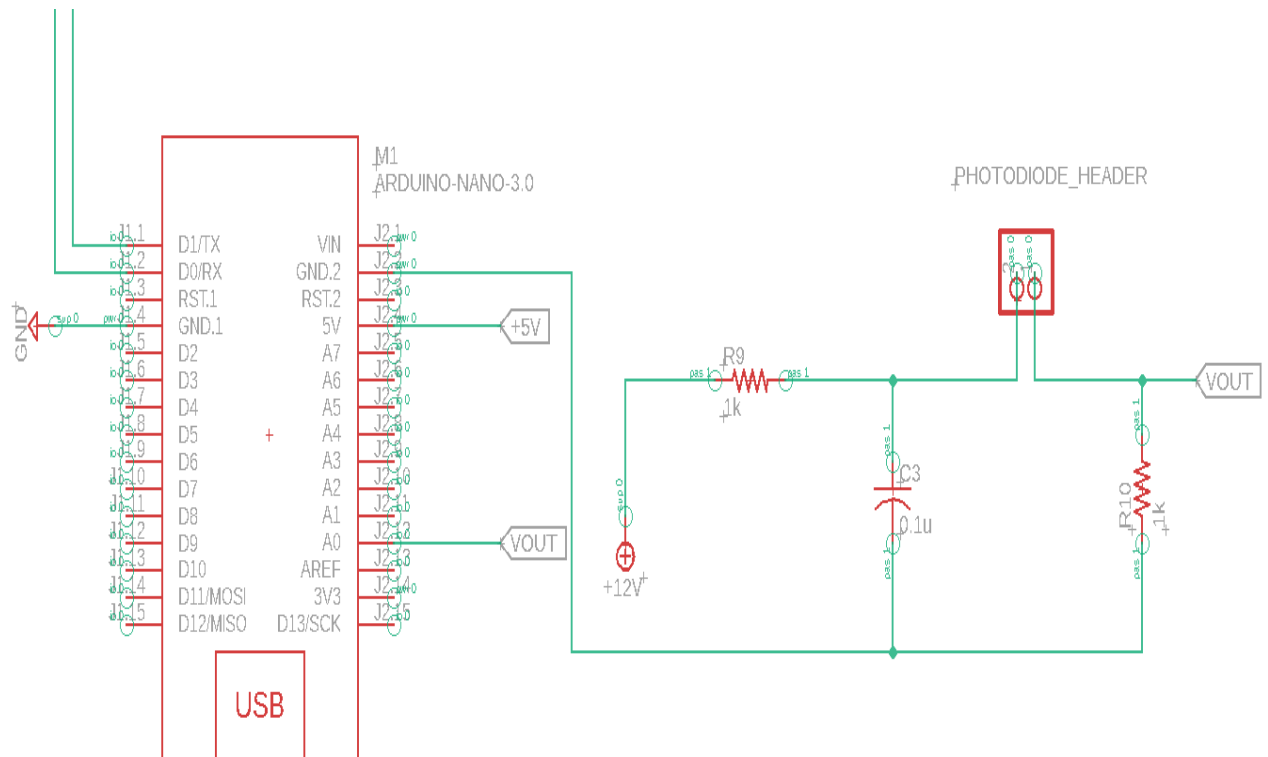

Figure 52 - Photodiode Circuit Schematic

The schematic above shows an additional header which will be used to connect the photodiode wires. A +12V bias voltage is connected to the diode circuit and it was carefully chosen so as to not exceed the maximum reverse bias voltage of the photodiode of +25V. The resistor R9 and the capacitor C3 form a 1st order lowpass filter which will filter out any high frequency noise in the circuit, the values were chosen according to the circuit diagram taken from the Thorlabs datasheet for the FDS1010 photodiode.

The resistor R10 is a load resistor and the voltage across this resistor labeled Vout is the voltage that will be connected to the A0 analog pin of the Arduino Nano which can perform ADC conversion. The value for this resistor appears as 1k $\Omega$  but more tests have to be done to obtain the responsivity of the photodiode to calculate the load resistor needed for a certain output voltage.

For the Arduino Nano in this schematic it will be powered using the output of the +5V regulator using the 5V pin. The Arduino Nano is also connected to the ground of the photodiode circuit and to the ground of the entire circuit. It can also be seen that the transmitter TXD and receiver RXD pins of the Arduino Nano are connected to the transmitter and receiver pins of the ESP32 as well in which the transmitter of each is connected to the receiver of the other. In this way both the Arduino Nano and the ESP32 can be connected and use Serial communication between each other to send the photodiode data received from the Arduino Nano to the ESP32 board.

The BOM for the photodiode circuit can be seen below:

Part Designator	Quantity	Value	Package	Manufacturer
R9	1	1k $\Omega$	R0805	Vishay
R10	1	-	R0805	Vishay
C3	1	0.1 $\mu$ F	C0805	Panasonic
PHOTODIODE_HEADE R	1	-	1X02	Glarks
M1	1	-	ARDUINO-NA NO-3.0	REXQualis

Table 22 - Photodiode Circuit BOM

As can be seen in the BOM above, the only component that will not be purchased yet is resistor R10 because tests on the responsivity will be done later on. The package and manufacturer however can be picked early on.

## 5.7. PIR Motion Sensor System Design

The PIR motion sensor will be used in an analog format to ensure constant detection of motion over a time interval of our choosing. The Alliedelec AMN 34111 is rated for four different modes of detection types. These modes can be switched to fit the needs of our smart window at will and the differing performances of each are listed below.

Detection Types	Standard Detection	Slight Motion Detection	Spot Detection	10 Meter Detection
Detection Distance	5 meters	2 meters	5 meters	10 meters
Horizontal Detection Angle	100 °	91 °	38 °	110 °
Vertical Detection Angle	82 °	91 °	22 °	93 °

Table 23 - Alliedelect AMN 34111 detection performances

The table above representing the different detection performances shows the benefits and drawbacks for each mode of the passive infrared motion sensor. The modes can be selected to maximize the performance of the system based on the needs of the user.

The image below represents a circuit diagram that will be used to allow for the motion sensor to operate inside of our smart window. As mentioned the circuit is designed for an analog output design.

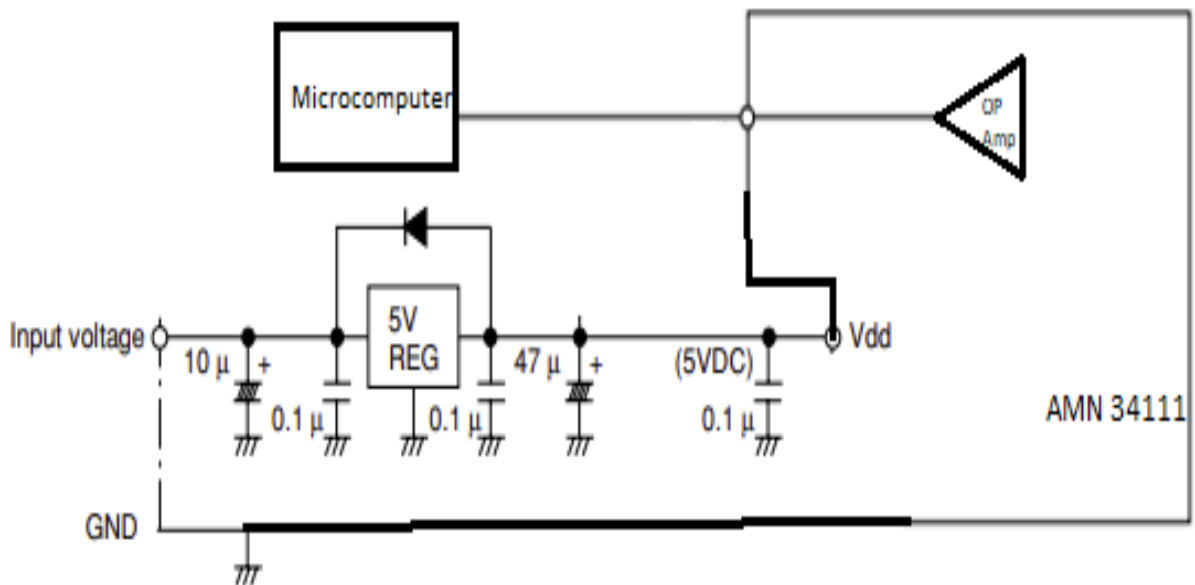

Figure 53 - Alliedelect AMN 34111 analog circuit (Panasonic recommendation circuit)

## AMN 34111 Alliedelec Specifications

In order to use the AMN 34111 motion sensor some basic operating specifications are listed below. All measurements will assume room temperature of 25 degrees celsius and are liable to change slightly in different temperatures.

Items	Values
<b>Operating Voltage</b>	4.5 V - 5.5 V DC
<b>Consumption Current</b>	170 $\mu$ a - 300 $\mu$ a
<b>Output Current</b>	50 $\mu$ a
<b>Output Voltage Range</b>	0 V to Vdd (circuit diagram)
<b>Output Offset Average Voltage</b>	2.3 V to 2.7 V
<b>Steady - State Noise</b>	155 m Vp-p to 300 m Vp-p
<b>Detection Sensitivity</b>	0.45 V
<b>Circuit stability time</b>	45 s

Table 24 - Alliedelec AMN 34111 analog specifications

This table provides all of the necessary information we will need to consider when building the circuit for the photodiode. We will be able to use this table and the circuit diagram in order to construct a working motion sensor and will be able to fine tune the specifications within the manufacture recommendations which will optimize the passive infrared motion sensor results.

## 5.8 Overall Schematic & PCB Layout

The overall schematic of the system combining all of the circuits designed is shown below with all of the circuits grouped by function in Eagle.



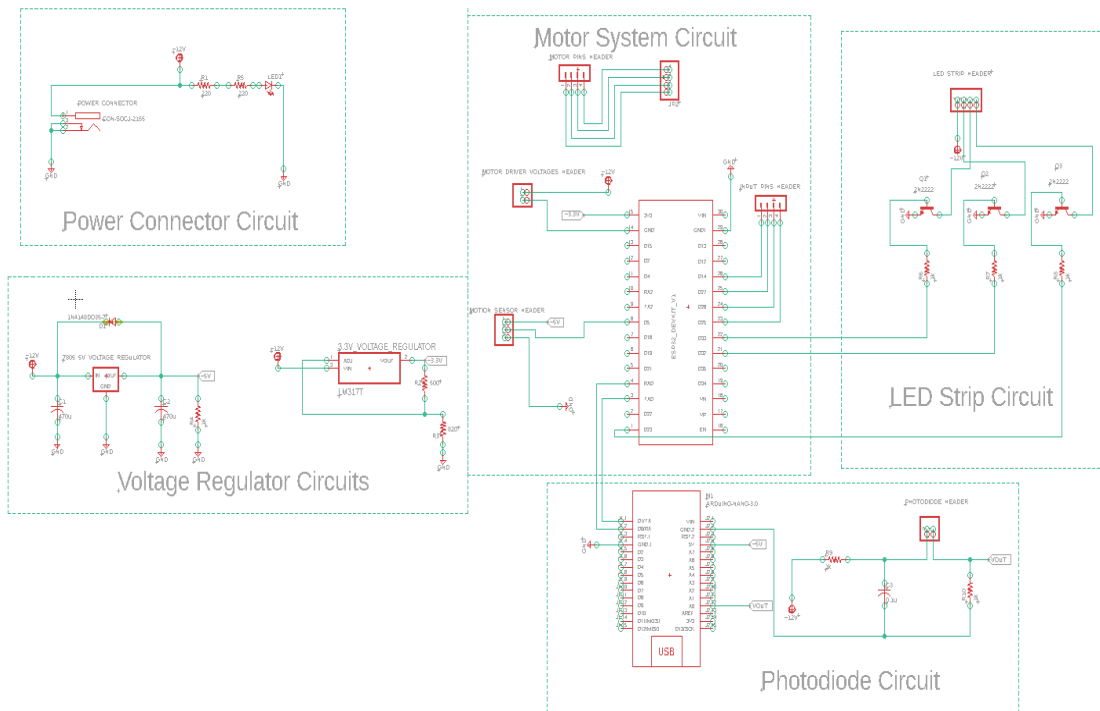

Figure 54 - Final PCB Schematic

The overall schematic for the autonomous smart window was then transferred to a PCB board. The PCB layout can be seen below and the final design turned out to be 4.11 inches wide and 3.51 inches wide which is relatively small and easy to mount. The ESP32 board was the only component for which a symbol had to be designed instead of finding one readily available. A footprint however for a different ESP32 version was available and the footprint was measured using the tools in Eagle to make sure that the dimensions of the two boards would match so that no two components are overlapping with one another.

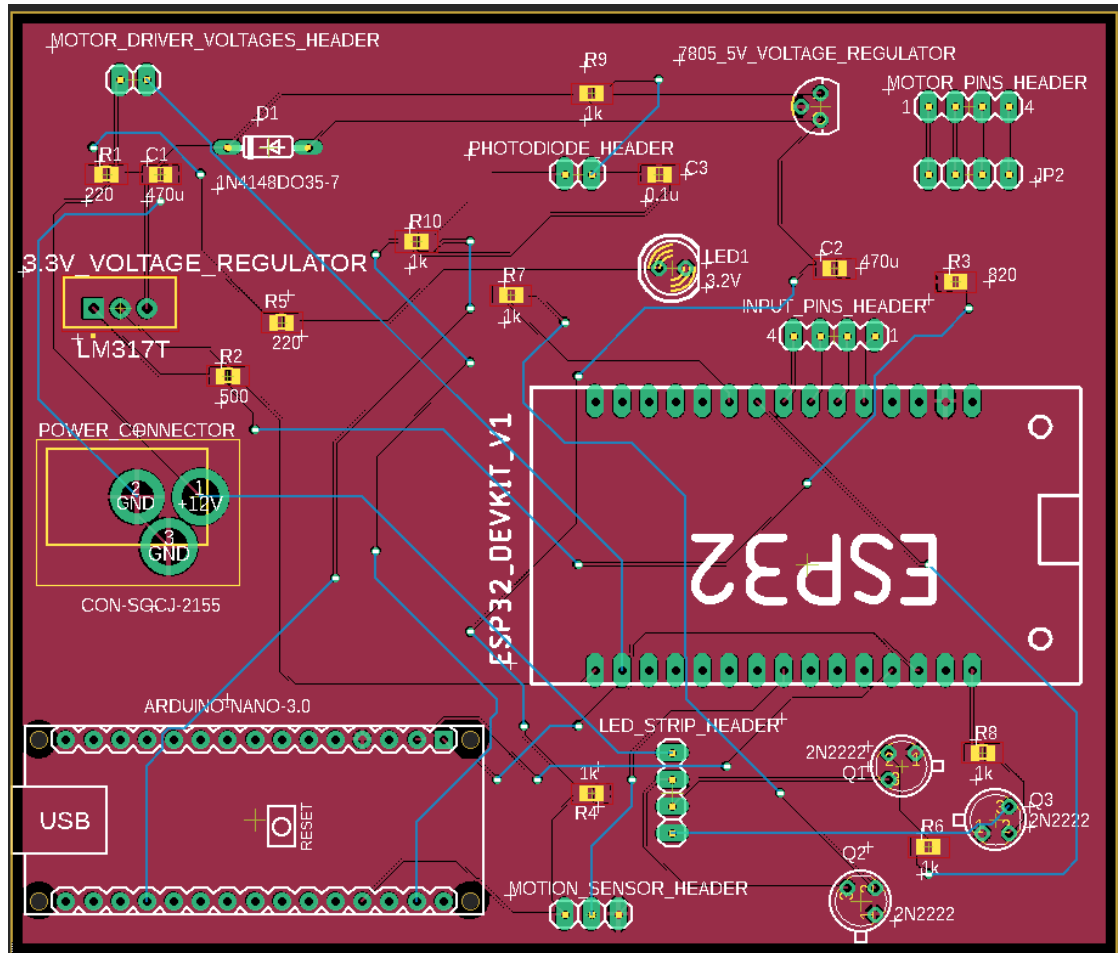

Figure 55 - PCB Layout in Eagle

The PCB board consists of two layers both of which are grounded to eliminate all of the ground routing that had to be done on both layers of the board. The largest components being the ESP32 board, the Arduino Nano and the power connector were all placed towards the edges of the board to allow for easy connection to USB cables and for the power connector. Placing those components in the middle of the board would make them harder to connect and to program for the components that require that function. The names of the components and values were also placed so that when the components are being soldered onto the board there will be no guesswork done as to which component goes where. The silkscreen was made white so that the components were easier to view and the green pads show how the holes in the real board are going to be placed.

## 6. Project Prototype Construction and Coding

This section will talk about the final plans for construction of the smart window project. It will talk about such details as the PCB vendor that is going to manufacture the board used for this project as well as the different characteristics of the final board designed. The final coding for all of the other subsystems will also be discussed in this section.

### 6.1 PCB Vendor & Assembly

The PCB manufacturer chosen for the smart window was OSH Park which featured the service of manufacturing 2-layer boards. The final board design was sent to OSH Park and the final board designed according to the manufacturer settings can be seen below which is what the final board will look like.

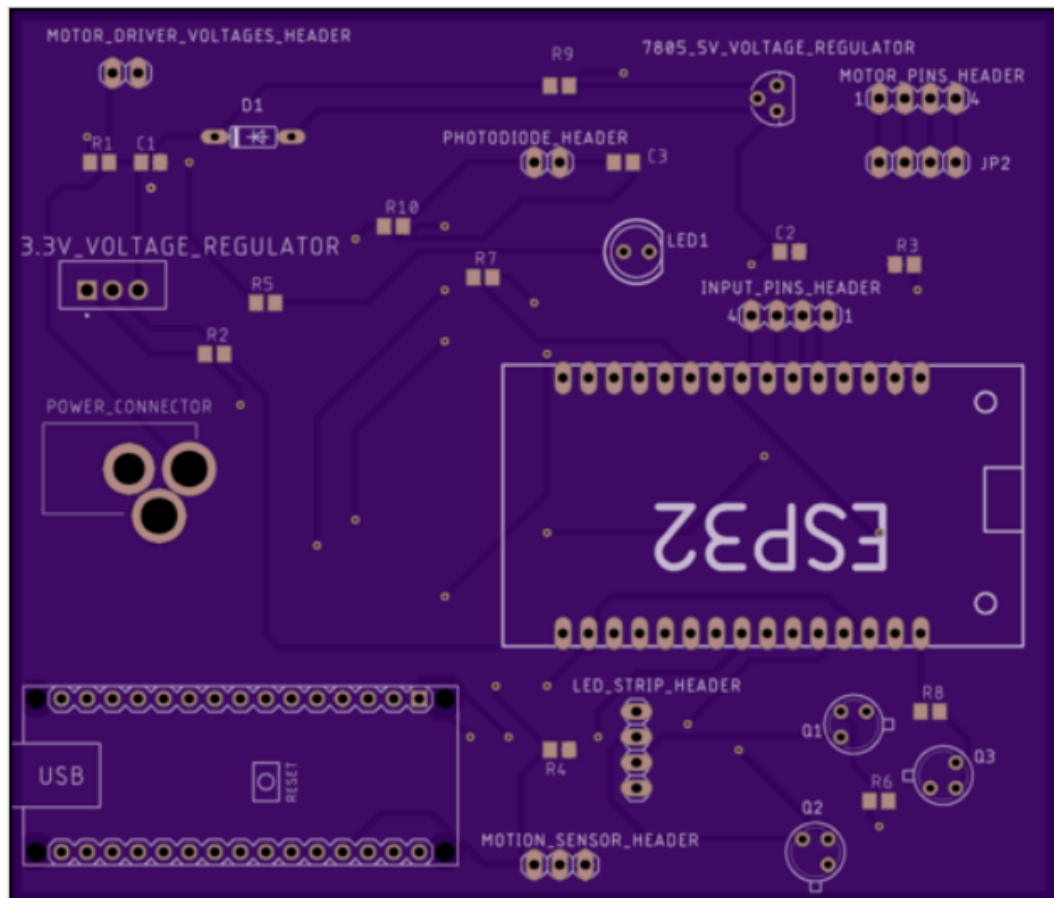

Figure 56 - PCB Board Prototype

The two layer Prototype service option offered by OSH Park would provide 3 copies of the board designed and the cost per square inch would be \$5.00. More copies of the board could be ordered as long as they were multiples of three. The shipping time of the boards would be 12 days according to the manufacturer website but most boards according to OSH Park will ship in 8 days.

This manufacturer also makes boards with a minimum size of 0.25 inches by 0.25 inches all the way to the maximum size of 16 inches by 22 inches and the board designed for this project is way within those bounds. The final cost of the boards including shipping will come up to \$72.15 which is a bit expensive but three copies will be obtained just in case something happens to the first one. The table below summarizes the characteristics of the manufacturer and board.

<b>Manufacturer &amp; Board Characteristics</b>	
Manufacturer	OSH Park
PCB Board Color	Purple
Shipping Speed (days)	9 - 12
# of Copies Obtained	3
Board Layers	2
Price per Square Inch (\$)	5.00
Dimensions of Board (inches)	4.11 x 3.51
Total Cost (3 Boards) (\$)	72.15

Table 25 - Manufacturer & Board Characteristics

The table above is the manufacturer specified characteristics for the PCB board that we will be using in our project. Some of the most important characteristics in the table are the dimensions, as it must fit inside the window frame. The time taken to receive the board must also be factored in as it will take a significant amount of time to ship the device and we need enough time to be able to solder the board and connect all of the window features.

It should also be mentioned that the board designed above has no holes where the resistors are supposed to go. The resistors should be easily soldered to the pads shown where the resistors are supposed to be on top instead of placing them through any holes which will still work with the resistors purchased.

The same effect will apply for the capacitors since there are no holes for them either. The rest of the components have holes and can be placed easily through the board. It should also be mentioned that the manufacturer design created an additional four holes at the edges of the Arduino Nano board which should not cause any issues because the board will be placed on top of these holes anyway.

## 7. Project Prototype Testing Plan

The plans for testing of the final smart window prototype will be discussed in this section to ensure that before the window prototype is to be constructed, there will already be a way to test each of the sub systems so that they all work together and no system fails or becomes damaged in the process.

### 7.1 Hardware Specific Testing

Hardware testing of the smart window will include the testing of the physical components that the smart window will contain including the PCB as well as the motor system and other subsystems.

#### PCB Testing

In order to test the PCB to make sure that everything is working as it should be an easy test can be done. The +12V power connector can be connected to the PCB board and if the LED that is attached to the PCB board lights up then we know the system is powered and that there is current flowing to all of the devices and that there is a 3.2V voltage drop across the LED. Just in case, multimeter probes can be used to measure the voltages across each of the resistors in the system to make sure that there are no short circuits in the system.

The voltages at the pin headers can also be measured with respect to ground to make sure they are giving the voltages that they are supposed to supply in the schematic. After finding the voltages across the resistors, the current in the system can be found easily through KVL, KCL, and Ohm's law to make sure that the rated current of 2A of the power adapter is not exceeded and is below this amount. A circuit simulator software such as Multisim can also be used before plugging in the power connector to the system as an additional safety measure.

Since the voltage regulators are also on the PCB they can be tested as well by again using a multimeter and measuring the voltage at the input and the voltage at the output for both regulators to make sure that a voltage of +5V and +3.3V is obtained for each of them respectively and that these values are not above those amounts because the other components may be damaged. The testing of the voltage regulators should be done before connecting the other devices as a precaution. To test the PCB only a multimeter is needed and this testing can be done anywhere.

## Motor System Testing

The motor system will be tested to ensure that the motor driver can control the stepper motor to perform a successful rotation of the window film. The motor will be installed in the pulley mechanism and the motor will be rotated according to the code on the ESP32 and the revolutions per minute of the stepper motor will be adjusted and the distance the window is rotated will be measured according to the rpm of the motor to see which rpm setting is best for getting the window film to rotate for the most optimal performance. The time it takes for the tinting effect of the window film will also be measured for each rpm setting to see what response time will be decided on for the final prototype of the window. The pulley system will be redesigned if when the motors rotate there is some error in the rotation of the film. The summary of the testing procedure for the motor system can be seen below.

Testing Step	Procedure
Step 1	Connect motor to PCB and L298N
Step 2	Install motor on pulley system
Step 3	Vary rpm in code from min to max
Step 4	Measure distance rotated by film
Step 5	Measured response time of the tinting of the window
Step 6	Redesign pulley system if necessary
Step 7	Choose rpm setting for motor

Table 26 - Motor System Testing Procedures

## 8. Administrative Content

This chapter provides all of the administrative content related to our project. All details related to our project budget as well as our project timeline are contained in this chapter.

### 8.1 Project Budget

The project budget is important for keeping track of our expenses, and to make sure that we are not spending too much money in an area where it is not necessary. We also want to keep track of which elements of our design are the most costly. Table 23 shows our initial budget estimation based on early research. We included constraints and specifications for each component since we created this budget during the very early stages of our design. The constraints and specs helped us put together a more accurate budget, although specifications and limitations have evolved over time. Table 24 contains our updated budget with the actual costs for items. The table is constantly being added to as we purchase more parts.



## Estimated Project Budget

Item Description	Quantity	Constraints/Specifications	Cost
PIR Motion Sensor	2	1.) Small enough to fit inside of 2 inch thick hollow window frame 2.) Connect to same arduino board as photometer	\$10
In-unit Photometer	1	1.) Be hardly visible to the user (small and semi-transparent) 2.) Must connect to same arduino board as photometer	\$70
Polarizer	3	1.) Needs to allow for at nearly 50% of transmission when all polarizers are aligned 2.) Thin enough to fit between panes	\$120
Privacy screen	1	1.) Ability to turn on and off with data from PIR 2.) Thin enough to fit into window	\$50
Arduino Bluetooth	1	1.) Connectable to any phone	\$5
PCB	1	1.) Must be able to connect all Arduino boards and run polarizer movements	\$50
Dual Pane Window	1	1.) At least 1 inch of gap in between pains 2.) Hollow window frame for mounting of electronics	\$140
LED strip	1	1.) Allow privacy screen to change color 2.) Diffuse light fully through the privacy screen	\$25
<b>Total cost</b>			<b>\$470</b>

Table 27 - Estimated Project Budget

## Items Purchased

<b>Item Description</b>	<b>Quantity</b>	<b>Model and Manufacturer</b>	<b>Cost</b>
PIR Motion Sensor	2	Panasonic AMN34111	\$29.14
Photodiode	1	FDS1010 Thorlabs	\$55.73
PDLC Privacy Screen	1	Invisishade Self-Adhesive Film	\$199.00
Motor Driver	1	SongHe L298N Motor Driver	\$8.71
Power Connector	1	Gravitech Item#:CON-SOCJ-2155	\$1.00
Power Adapter	1	TMEZON 12V 2A Power Adapter	\$7.99
Voltage Regulators	2	LM317T & 7085 On Semiconductor & Texas Instruments	\$0.95
Processor	1	MELIFE ESP32	\$6.00
Bearing	1	TROOPS BBQ Lazy Susan Turntable Ring	\$35.00
Timing Belt	1	KeeYees 5M GT2	\$15.99
Arduino Nano V3.0	1	REXQualis Nano V3.0, Nano Board CH340	\$13.86
Linear Polarizers	2	AFLASH PF030 Fully Laminated Polarizers	\$118.00

Table 28 - Purchased Parts

## 8.2 Project Milestones and Timeline

This section will detail the important milestones that will be met during the course of this project. It will show the beginning of the project starting in Senior Design 1 in Fall 2020 and will include times for research of different technologies and will end at the end of Senior Design 2 in Spring 2021 the final window prototype.

Number	Task	Start	End
<b>Senior Design 1</b>			
1	Discuss Ideas	8/25/20	9/18/20
2	Divide & Conquer Doc	9/11/20	9/18/20
3	Motor Driver	9/11/20	10/2/20
4	IR Motion Sensors	9/11/20	9/25/20
5	Privacy Films	9/11/20	9/25/20
6	Photometer	9/26/20	10/2/20
7	PCB Layout	10/3/20	10/16/20
8	Power Supply	10/3/20	10/16/20
9	Phone App	10/17/20	10/31/20
10	Order Parts	11/1/20	11/30/20
11	Final Report	11/9/20	12/8/20
<b>Senior Design 2</b>			
12	Redesign	TBA	TBA
13	Prototype	TBA	TBA
14	Final Report	TBA	TBA

Table 29 - Milestones and Timeline